



SERVICE MANUAL

UHF FM TRANSCEIVER

IC-F410

IC-F410S

IC-F420

IC-F420S

INTRODUCTION

This service manual describes the latest service information for the **IC-F410**, **IC-F410S**, **IC-F420** and **IC-F420S** UHF FM TRANSCEIVERS at the time of publication.

To upgrade quality, any electrical or mechanical parts and internal circuits are subject to change without notice or obligation.

DANGER

NEVER connect the transceiver to an AC outlet or to a DC power supply that uses more than 16 V. This will ruin the transceiver.

DO NOT expose the transceiver to rain, snow or any liquids.

DO NOT reverse the polarities of the power supply when connecting the transceiver.

DO NOT apply an RF signal of more than 20 dBm (100 mW) to the antenna connector. This could damage the transceiver's front end.



ORDERING PARTS

Be sure to include the following four points when ordering replacement parts:

1. 10-digit order numbers
2. Component part number and name
3. Equipment model name and unit name
4. Quantity required

<SAMPLE ORDER>

1150001670 IC SC-1322 IC-F410 MAIN UNIT 5 pieces
8810005840 Screw PH BT M3 x 8 NI-ZU IC-F410 Bottom cover 10 pieces

Addresses are provided on the inside back cover for your convenience.

REPAIR NOTES

1. Make sure a problem is internal before disassembling the transceiver.
2. **DO NOT** open the transceiver until the transceiver is disconnected from its power source.
3. **DO NOT** force any of the variable components. Turn them slowly and smoothly.
4. **DO NOT** short any circuits or electronic parts. An insulated tuning tool **MUST** be used for all adjustments.
5. **DO NOT** keep power ON for a long time when the transceiver is defective.
6. **DO NOT** transmit power into a signal generator or a sweep generator.
7. **ALWAYS** connect a 50 dB to 60 dB attenuator between the transceiver and a deviation meter or spectrum analyzer when using such test equipment.
8. **READ** the instructions of test equipment thoroughly before connecting equipment to the transceiver.

EXPLICIT DEFINITIONS

• IC-F410/F410S [PMR (Personal Mobile Radio)]

	Frequency Coverage	Channel Spacing
L-band	400–430 MHz	25/12.5 kHz
ML-band	440–470 MHz	25/12.5 kHz
MH-band	470–490 MHz	25/12.5 kHz
H-band	490–520 MHz	25/12.5 kHz

• IC-F420/F420S [LMR (Land Mobile Radio)]

	Frequency Coverage	Channel Spacing
L-band	400–430 MHz	25/12.5 kHz
ML-band	450–470 MHz	25/12.5 kHz
MH-band	470–490 MHz	25/12.5 kHz
H-band	490–512 MHz	25/12.5 kHz

TABLE OF CONTENTS

SECTION 1 SPECIFICATIONS

SECTION 2 INSIDE VIEW

SECTION 3 DISASSEMBLY INSTRUCTIONS

SECTION 4 CIRCUIT DESCRIPTION

4 - 1	RECEIVER CIRCUITS	4 - 1
4 - 2	TRANSMITTER CIRCUITS	4 - 2
4 - 3	PLL CIRCUITS	4 - 3
4 - 4	POWER SUPPLY CIRCUITS	4 - 4
4 - 5	PORT ALLOCATIONS	4 - 4

SECTION 5 ADJUSTMENT PROCEDURES

5 - 1	PREPARATION	5 - 1
5 - 2	PLL ADJUSTMENT	5 - 3
5 - 3	TRIMMER ADJUSTMENT	5 - 4
5 - 4	BEEP ADJUSTMENT	5 - 6

SECTION 6 PARTS LIST

SECTION 7 MECHANICAL PARTS

SECTION 8 SEMI-CONDUCTOR INFORMATION

SECTION 9 BOARD LAYOUTS

9 - 1	FRONT UNIT (IC-F410/F420)	9 - 1
9 - 2	FRONT UNIT (IC-F410S/F420S)	9 - 3
9 - 3	MAIN UNIT	9 - 5

SECTION 10 BLOCK DIAGRAM

SECTION 11 VOLTAGE DIAGRAM

11 - 1	FRONT UNIT	11 - 1
11 - 2	MAIN UNIT	11 - 2

SECTION 1 SPECIFICATIONS

			IC-F410/F410S (PMR)	IC-F420/F420S (LMR)	
GENERAL	Measurement method		ETS 300 086	EIA/TIA-152C/204D	
	Frequency coverage		400–430 MHz 440–470 MHz 470–490 MHz 490–520 MHz	400–430 MHz 450–470 MHz 470–490 MHz 490–512 MHz	
	Number of channels		F410 : 32 (16 ch × 2 banks) F410S: 8 ch, or 4 ch × 2 banks	F420 : 32 (16 ch × 2 banks) F420S: 4 ch	
	Type of emission		16K0F3E (25 kHz; Wide) 8K50F3E (12.5 kHz; Narrow)		
	Frequency stability		±1500 Hz	±0.0005%	
	Operating temperature range		–20°C to +55°C	–30°C to +60°C; –22°F to +140°F	
	Power supply voltage		13.2 V DC (negative ground)	13.6 V DC (negative ground)	
	Current drain (approx.)	TX	max. power	7.0 A (at 25 W) / 5.0 A (at 10 W)	10.0 A (at 35 W)
		RX	max. audio	700 mA	
			stand-by	200 mA	
	Antenna connector		SO-239 (50 Ω)		
	Dimensions (proj. not included)		140(W) × 40(H) × 170(D) mm; 5½(W) × 1⅞(H) × 6⅛(D) inch		
	Weight		1.2 kg; 2 lb 10 oz		
TRANSMITTER	Output power		25 W / 10 W	35 W	
	Modulation system		Variable reactance frequency modulation		
	Max. frequency deviation		±5.0 kHz (Wide) ±2.5 kHz (Narrow)		
	Spurious emissions		0.25 μW	70 dB	
	Adjacent channel power		70 dB (Wide) 60 dB (Narrow)		
	Residual modulation		55 dB typical (Wide) 50 dB typical (Narrow)	46 dB typical (Wide) 40 dB typical (Narrow)	
	Limiting		60–100 % of modulation		
	Microphone connector		8-pin modular (600 Ω)		
RECEIVER	Intermediate freq.		1st: 46.35 MHz 2nd: 450 kHz		
	Sensitivity (typical)		–2 dBμV (emf) at 20 dB SINAD	0.25 μV typical at 12 dB SINAD	
	Squelch sensitivity		–2 dBμV (emf)	0.25 μV typical	
	Adjacent channel selectivity		70 dB (Wide) 60 dB (Narrow)		
	Spurious response		70 dB		
	Intermodulation		65 dB		
	Hum and noise		50 dB typical (Wide) 45 dB typical (Narrow)	46 dB typical (Wide) 40 dB typical (Narrow)	
	Audio output power		3.5 W typical at 5% distortion with a 4 Ω load		
	External SP connector		2-conductor 3.5 (d) mm (1/8")/4 Ω		

All stated specifications are subject to change without notice or obligation.

SECTION 2 INSIDE VIEW

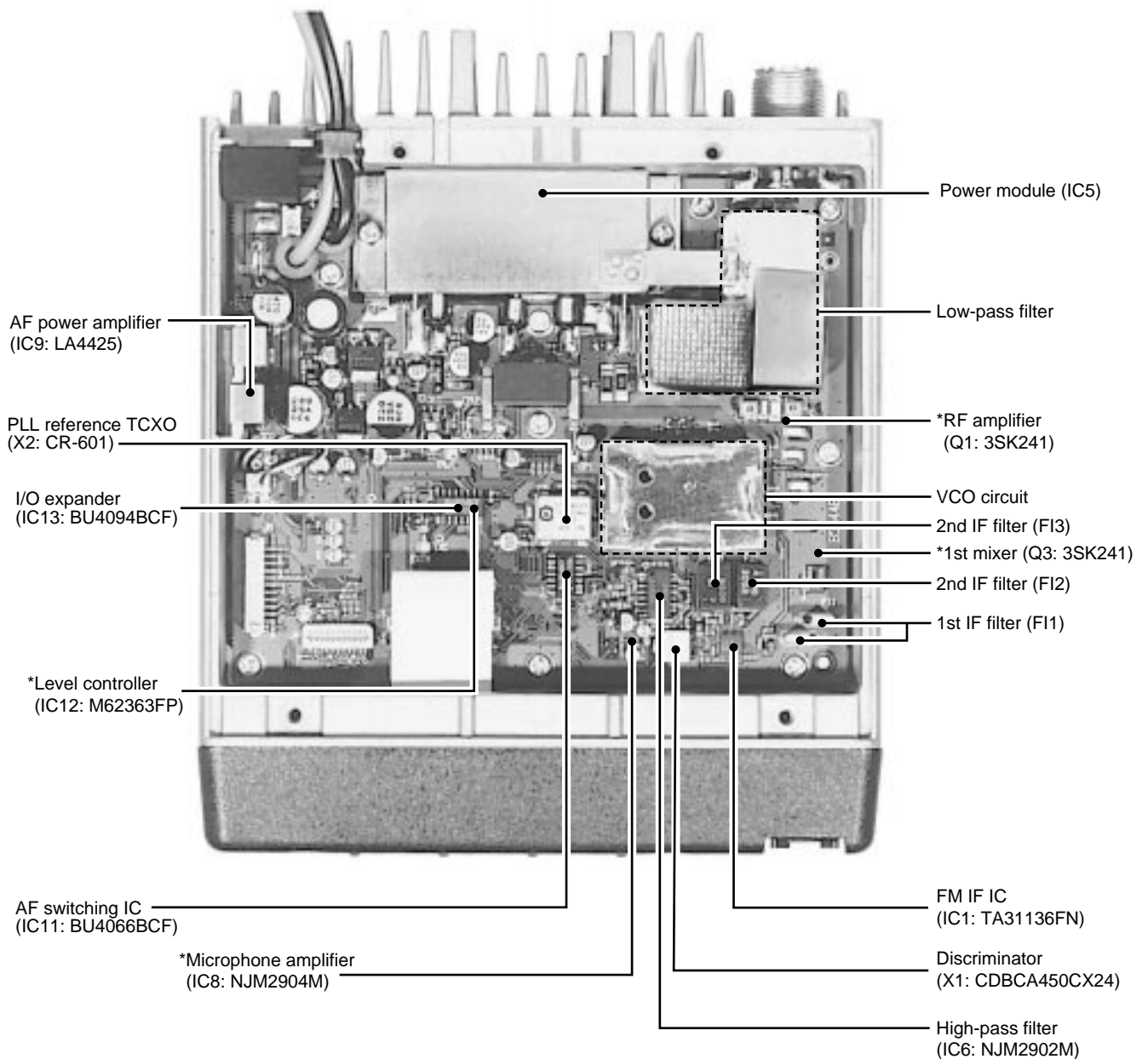

Note:

* Located under side of the point.

SECTION 3 DISASSEMBLY INSTRUCTIONS

- Opening case

- ① Unscrew 4 screws, (A), and remove the bottom cover.
- ② Unscrew 2 screws, (B), and remove the front case.

- ⑥ Lift the front portion of the main unit and remove it.

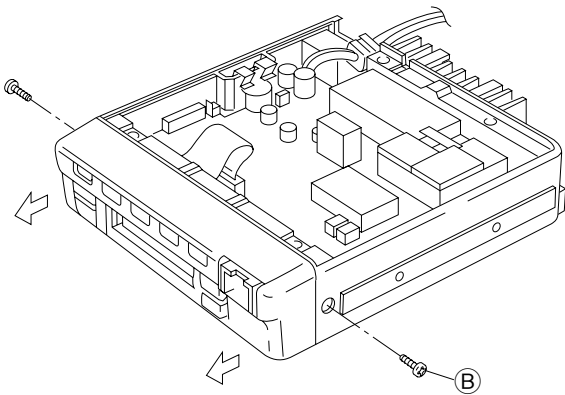
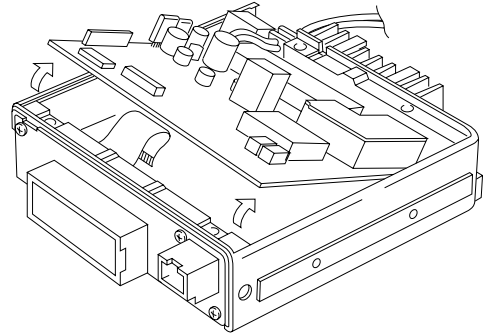
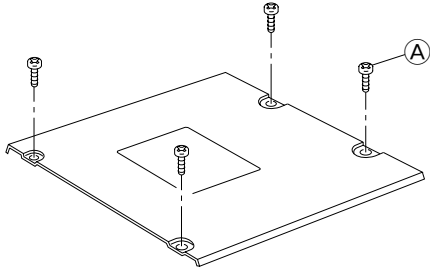

- Installation location
 UT-96 TONE UNIT
 UT-105 SmarTrank 2™ Logic Board

- ③ Unscrew 10 screws, (C), and remove 2 clips, (D).
- ④ Remove shield case, (E).
- ⑤ Unsolder 3 points, (F), from the antenna connector.

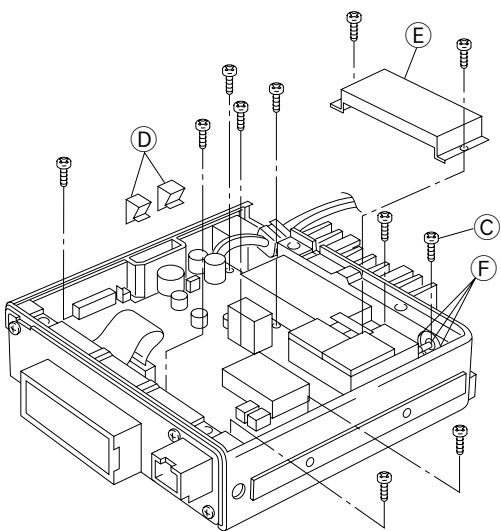
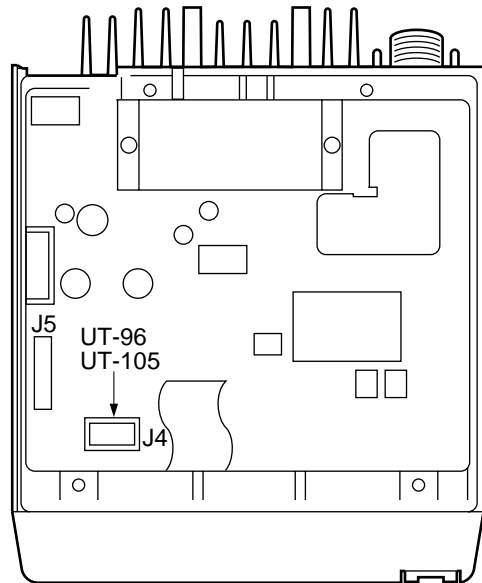

SECTION 4 CIRCUIT DESCRIPTION

4-1 RECEIVER CIRCUITS

4-1-1 ANTENNA SWITCHING CIRCUIT (MAIN unit)

The antenna switching circuit functions as a low-pass filter while receiving and as resonator circuit while transmitting. The circuit does not allow transmit signals to enter receiver circuits.

Received signals enter the antenna connector and pass through the low-pass filter (L1–L3, C1, C2, C9–12). The filtered signals are then applied to the RF circuit passed through the $\lambda/4$ type antenna switching circuit (D4, D5, L5).

4-1-2 RF CIRCUIT (MAIN unit)

The RF circuit amplifies signals within the range of frequency coverage and filters out-of-band signals.

The signals from the antenna switching circuit pass through the attenuator circuit (D4, D5) and the two-stage tunable bandpass filters (D7, D8). The filtered signals are amplified at the RF amplifier (Q2) and then enter other two-stage bandpass filters (D9, D10) to suppress unwanted signals. The filtered signals are applied to the 1st mixer circuit (Q3).

The tunable bandpass filters (D7–D10) employ varactor diodes to tune the center frequency of the RF passband for wide bandwidth receiving and good image rejection. These diodes are controlled by the CPU (FRONT unit; IC1) via the level controller (IC12).

The attenuator circuit (D4, D5) functions only when the attenuator function is assigned to a programmable key and turns on to protect the RF amplifier from distortion caused by receiving excessively strong signals.

When the attenuator function is turned on, the CPU (FRONT unit; IC1, pin 32) switches the voltage level of the "RF ATT" line from high to low and then controls the attenuator switch (Q1). In this case, the current of D4, D5 is increased and D4, D5 act as an attenuator.

4-1-3 1ST MIXER AND 1ST IF CIRCUITS (MAIN unit)

The 1st mixer circuit converts the received signals to a fixed frequency of the 1st IF signal with the PLL output frequency. By changing the PLL frequency, only the desired frequency will pass through a pair of crystal filters at the next stage of the 1st mixer.

The RF signals from the bandpass filter are applied to the 1st mixer circuit (Q3). The applied signals are mixed with the 1st LO signal coming from the RX VCO circuit (Q23) to produce a 46.35 MHz 1st IF signal. The 1st IF signal passes through a pair of crystal filters (F1a/b) to suppress out-of-band signals. The filtered signal is amplified at the 1st IF amplifier (Q4) and applied to the 2nd IF circuit.

4-1-4 2ND IF AND DEMODULATOR CIRCUITS (MAIN unit)

The 2nd mixer circuit converts the 1st IF signal to a 2nd IF signal. A double-conversion superheterodyne system improves the image rejection ratio and obtains stable receiver gain.

The 1st IF signal from the IF amplifier (Q4) is applied to the 2nd mixer section of the FM IF IC (IC1, pin 16) and is then mixed with the 2nd LO signal for conversion to a 450 kHz 2nd IF signal.

IC1 contains the 2nd mixer, limiter amplifier, quadrature detector, active filter and noise amplifier circuits, etc. A tripled frequency from the PLL reference oscillator is used for the 2nd LO signal (45.9 MHz).

The 2nd IF signal from the 2nd mixer (IC1, pin 3) passes through ceramic filters (F12 and F13) during narrow channel spacing selection or passes through F12 (bypassing F13) only during wide channel spacing selection. It is then amplified at the limiter amplifier section (IC1, pin 5) and applied to the quadrature detector section (IC1, pins 10, 11 and X1) to demodulate the 2nd IF signal into AF signals.

The AF signals are output from pin 9 (IC1) and are then applied to the AF amplifier circuit.

• 2nd IF and demodulator circuits

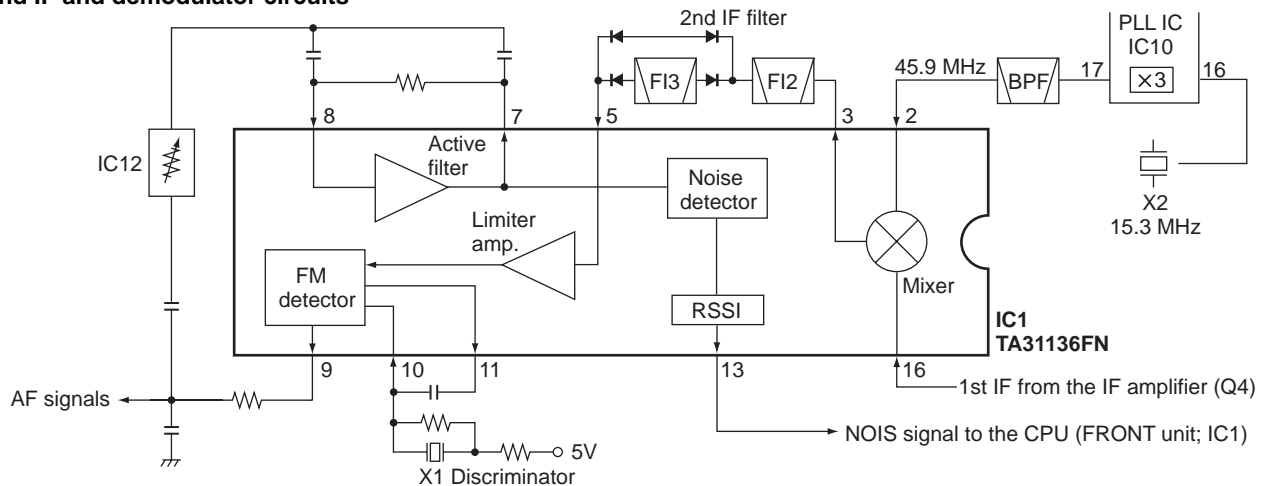

4-1-5 AF AMPLIFIER CIRCUIT (MAIN unit)

The AF amplifier circuit amplifies the demodulated AF signals to drive a speaker.

AF signals from the FM IF IC (IC1, pin 9) are amplified at the AF amplifier (IC7a) and then pass through the high-pass filter (IC6) whose characteristics are controlled by the "AFHPF" line. When "AFHPF" is at a high level, the cut off frequency is shifted higher to remove CTCSS or DTCS signals.

The filtered signals from IC6 (pin 14) pass through the AF switching IC (IC11, pin 8, 9) and are applied to the level controller (IC12, pin 16, 15). The audio level controlled signals are again passed through the AF switching IC (IC11, pin 2, 1), applied to the de-emphasis circuit (IC4) with frequency characteristics of -6 dB/octave, and are then power amplified at the AF amplifier (IC9) to drive a speaker.

4-1-6 RECEIVER MUTE CIRCUITS (MAIN and FRONT units)

• NOISE SQUELCH

The noise squelch circuit cuts out AF signals when no RF signals are received. By detecting noise components in the AF signals, the squelch circuit switches the AF mute switch.

A portion of the AF signals from the FM IF IC (IC1, pin 9) are applied to the level controller (IC12, pin 24). The level controlled noise components are output from pin 23 and are applied to the active filter in IC1 (pin 8). Noise components are amplified and output from pin 7 and are then applied to the noise detector section (pins 10, 11). The detected noise signals are rectified and output from pin 13 without smoothing.

The noise signal (NOIS) from IC1 (pin 13) is applied to the CPU (FRONT unit; IC1, pin 19). The CPU analyzes the noise condition and outputs the RMUT signal via the I/O expander IC (IC13) to toggle the AF mute switches (IC11a).

• CTCSS AND DTCS

The tone squelch circuit detects AF signals and opens the squelch only when receiving a signal containing a matching subaudible tone (CTCSS or DTCS). When tone squelch is in use, and a signal with a mismatched or no subaudible tone is received, the tone squelch circuit mutes the AF signals even when noise squelch is open.

• AF circuit

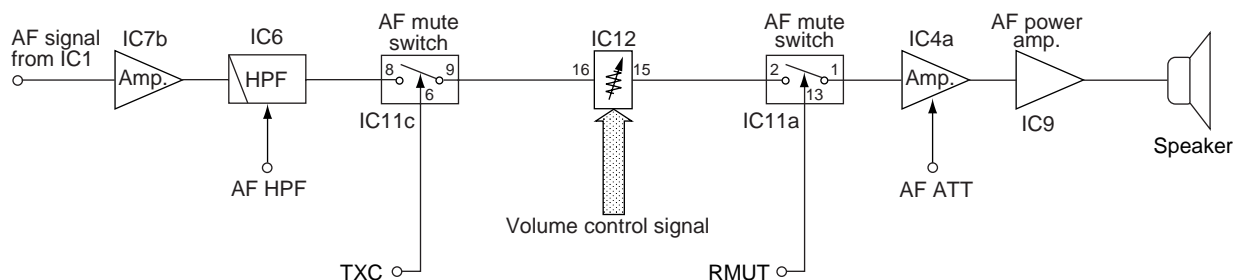

A portion of the AF signals from the AF amplifier (IC7b) passes through the low-pass filter (FRONT unit; Q5) to remove AF (voice) signals and is applied to the CTCSS or DTCS decoder inside the CPU (FRONT unit; IC1, pin 97) via the "CTCIN" line to control the AF mute switch via the I/O expander IC (IC13).

4-2 TRANSMITTER CIRCUIT

4-2-1 MICROPHONE AMPLIFIER CIRCUIT (MAIN unit)

The microphone amplifier circuit amplifies the audio signals from the microphone, within +6 dB/octave pre-emphasis characteristics, to a level needed for the modulation circuit.

The AF signals from the microphone are amplified at the AF (IC8b) and limiter (IC8a) amplifiers and are then passed through the pre-emphasis circuit (R152, C180) which has +6 dB/octave pre-emphasis characteristics.

The pre-emphasized signals are passed through the splatter filter (IC7a) and are then applied to the AF switching IC (IC11, pins 11, 10).

The signals are applied to the level controller (IC12, pins 16, 15). The deviation level controlled signals are passed through the AF switching IC (IC11, pins 3, 4), and are then applied to modulation circuit as the "MOD" signal.

The narrow/wide switch (Q35) is connected to the input of the splatter filter (IC7a) and switched by the "NWC" signal coming from the I/O expander IC (IC13). When "NWC" is at a high level, the narrow/wide switch (Q35) shifts the filter cut-off frequency for narrow deviation selection.

4-2-2 MODULATION CIRCUIT (MAIN unit)

The modulation circuit modulates the VCO oscillating signal (RF signal) using the microphone AF signals.

The "MOD" signals from the AF switching IC (IC11, pin 4) change the reactance of D21 to modulate the oscillated signal at the TX VCO circuit (Q25). The modulated signal is amplified at the buffer amplifiers (Q28, Q30) and is then applied to the drive amplifier circuit.

4-2-3 DRIVE AMPLIFIER CIRCUIT (MAIN unit)

The drive amplifier circuit amplifies the VCO oscillating signal to the level needed at the power amplifier.

The RF signal from the buffer amplifier (Q30) passes through the T/R switch (D18) and is amplified at the buffer (Q21, Q20) and drive (Q19) amplifiers. The amplified signal is applied to the power amplifier circuit.

4-2-4 POWER AMPLIFIER CIRCUIT (MAIN unit)

The power amplifier circuit amplifies the driver signal to an output power level.

The RF signal from the drive amplifier (Q19) is applied to the power module (IC5) to obtain 35 W (for IC-F420/F420S; 25 W for IC-F410/F410S) of RF power.

The amplified signal is passed through the antenna switching circuit (D3), low-pass filter and APC detector, and is then applied to the antenna connector.

Collector voltages for the driver (Q19) and control voltage for the power amplifier (IC5, pin 2) come from the APC controller (Q17, Q18) to stabilize the output power. The transmit mute switch (Q16) controls the APC controller when transmit mute is necessary.

4-2-5 APC CIRCUIT (MAIN unit)

The APC circuit protects the power amplifier from a mismatched output load and stabilizes the output power.

The APC detector circuit (D1) detects forward signals and reflection signals. The combined voltage is at minimum level when the antenna impedance is matched at 50 Ω and is increased when it is mismatched.

The detected voltage is applied to the inverse amplifier (IC4b, pin 6), and the power setting voltage (T4) is applied to the other input (pin 5) for the reference. When antenna impedance is mismatched, the detected voltage exceeds the power setting voltage. The output voltage of the inverse amplifier (IC4b, pin 7) controls the input current of the power module (IC5) and drive amplifier (Q19) to reduce the output power via the APC controller (Q17, Q18).

4-3 PLL CIRCUITS

4-3-1 PLL CIRCUIT

A PLL circuit provides stable oscillation of the transmit frequency and receive 1st LO frequency. The PLL circuit consists of the PLL IC (IC2), loop filter and reference oscillator circuit and employs a pulse swallow counter.

An oscillated signal from the VCO (Q23, Q25) passes through the buffer amplifiers (Q28, Q29), is applied to the PLL IC (IC10, pin 2) and is prescaled in the PLL IC based on the divided ratio (N-data). The reference signal is generated at the reference oscillator (X2) and is also applied to the PLL IC. The PLL IC detects the out-of-step phase using the reference frequency and outputs it from pin 8. The output signal is passed through the loop filter (Q34, R180, R181, C203, C231) and is then applied to the VCO circuit as the lock voltage.

4-3-2 VCO CIRCUIT (MAIN unit)

The VCO circuit contains a separate RX VCO (Q23, D20, D34) and TX VCO (Q25, D22, D33). The oscillated signal is amplified at the buffer amplifiers (Q28, Q29) and is then applied to the T/R switching circuit (D18, D19). The Rx signal is applied to the 1st mixer circuit (Q3) and the Tx signal to the driver (Q19) via the buffer amplifiers (Q21, Q20).

A portion of the signal from Q28 is amplified at the buffer amplifier (Q29) and is then fed back to the PLL IC (IC10, pin 2).

• PLL circuit

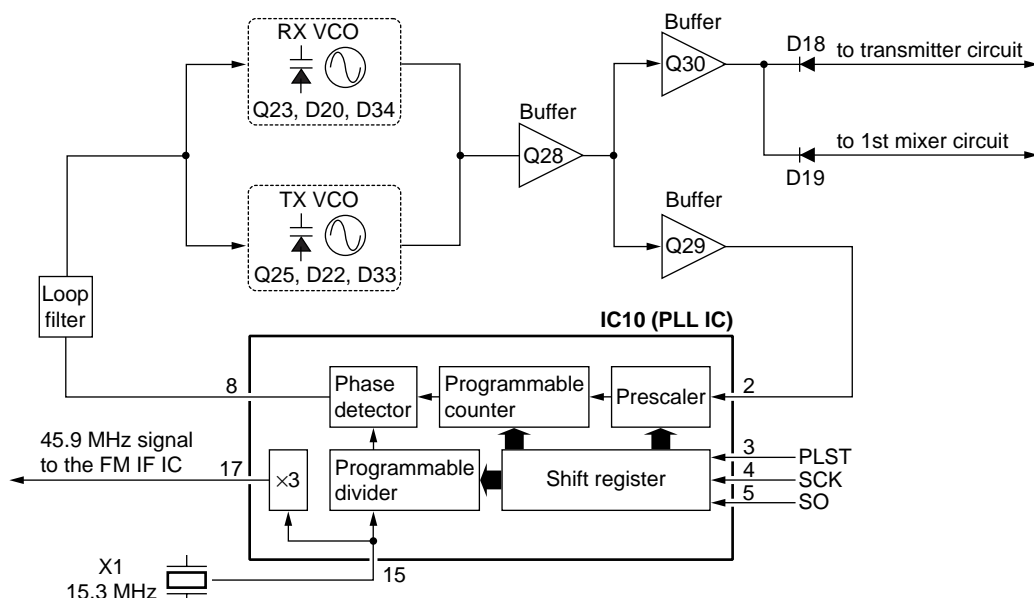

4-4 POWER SUPPLY CIRCUITS

4-4-1 VOLTAGE LINES (MAIN unit)

Line	Description
VCC	The voltage from a DC power supply.
HV	The same voltage as the VCC line which is controlled by the power switching circuit (Q14, Q15). When the [POWER] switch is pushed, the CPU outputs the "PWON" control signal to the power switching circuit to turn the circuit ON.
CPU5V	Common 5 V for the CPU converted from the VCC line by the CPU5V regulator circuit (IC3). The circuit outputs the voltage regardless of the power ON/OFF condition.
8V	Common 8 V converted from the HV line by the 8V regulator circuit (IC2).
5V	Common 5 V converted from the HV line by the 5V regulator circuit (Q12, Q13).
R8	Receive 8 V controlled by the R8 regulator circuit (Q10, Q11) using the "TXC" signal from the I/O expander IC (IC13).
T8	Transmit 8 V controlled by the T8 regulator circuit (Q8, Q9) using the "TXC" signal from the I/O expander IC (IC13).

4-5 PORT ALLOCATIONS

4-5-1 CPU (FRONT unit; IC1)

Pin number	Port name	Description
1	VIN	Input port for overvoltage detection from the connected power supply.
12	SCK	Outputs clock signal to the EEPROM (IC3), PLL IC (MAIN unit; IC10) and expander ICs (MAIN unit; IC12, IC13), etc.
13	SI	Input port for the data signals from the EEPROM (IC3), etc.
14	SO	Outputs data signals to the EEPROM (IC3), PLL IC (MAIN unit; IC10) and expander ICs (MAIN unit; IC12, IC13), etc.
16	CLIN	Input port for the cloning signal.
17	CLOUT	Output port for the cloning signal.
18	POSW	Input for the POWER switch. Low : While POWER switch is pushed.
19	NOIS	NOIS signal input port from the FM IF IC (MAIN unit; IC1) for noise squelch operation.
26	PTT	Input port for the PTT switch. Low : While PTT switch is pushed.

CPU (IC1)—continued

Pin number	Port name	Description
32	RFATT	Outputs RF attenuator control signal to the attenuator switch (MAIN unit; Q1). Low : While attenuator function is ON.
36	UNLK	Input port for PLL unlock signal from the PLL IC (MAIN unit; IC10). High: During unlock.
37	PWON	Outputs control signal for the power switching circuit (MAIN unit; Q14, Q15).
38	DIM	Outputs control signal for LCD backlight. Low : While LCD backlight is ON.
39	EXTPTT	Input port for the PTT switch from the external connector (MAIN unit; J5). Low : External PTT switch is ON.
40	DIMIN	Input port for the LCD backlight control signal from the external connector (MAIN unit; J5). Low : External dimmer switch is ON.
41	PLST	Outputs strobe signals for the PLL IC (MAIN unit; IC10).
42	DAST	Outputs strobe signals for the level controller IC (MAIN unit; IC12).
43	EXST	Outputs strobe signals for the I/O expander IC (MAIN unit; IC13).
45, 46	KS1, KS0	Output ports for the key matrix.
47–50	KR3–KR0	Input ports for the key matrix.
51	BM	Outputs control signal for the beep mute circuit (Q10). High: Beep muted.
52–54	CTDA0–CTDA2	Output ports for the CTCSS/ DTCS signals.
55	HANG	Input port for the microphone hanger detection signal. Low : Microphone on hook
90	MTONE	Output port beep audio while receiving. 2/5 tone signals while transmitting.
91	TONED	Outputs DTMF signals.
94–96	OPV3–OPV1	Input port for the option connector state (MAIN unit; J4).
97	CTCIN	Input port for the CTCSS/DTCS decode signals.
98	SD	Input port for S-meter signal.
99	LVIN	Input port for PLL lock voltage.
100	TEMP	Input port for the transceiver's internal temperature.

4-5-2 I/O expander IC

(1) IC12 (MAIN unit)

Pin number	Port name	Description
2, 3, 10	T1–T3	Output tunable band pass filter control signals.
11	T4	Output port for tunable band pass filter control signal while receiving. output power control signal while transmitting.
14	REF	Output port for reference frequency control voltage.

(2) IC13 (MAIN unit)

Pin number	Port name	Description
4	TXC	Outputs control signal for the R8 regulator circuits (MAIN unit; Q10, Q11). High: While transmitting.
5	TMUT	Outputs control signal for the T8 regulator circuits (MAIN unit; Q8, Q9). High: While Tx is muted.
6	RM	Outputs AF mute switch (MAIN unit; IC11) control signal for the receiver circuit. High: While no receive audio is emitted.
7	MM	Outputs MIC mute control signal. High: While DTMF signals are output, etc.
11	HORNO	Outputs external device control signal. High: When matched 2/5-tone signals are received.
12	AFATT	Outputs control signal for the AF amplifier regulator circuit. High: When squelch is open, etc.
13	AFHPF	Outputs AF filter control signal. High: Filters out CTCSS or DTCS frequency.
14	NWC	Outputs receive/transmit passband width control signal. High: While narrow bandwidth is selected.

SECTION 5 ADJUSTMENT PROCEDURES

5-1 PREPARATION

■ REQUIRED TEST EQUIPMENT

EQUIPMENT	GRADE AND RANGE	EQUIPMENT	GRADE AND RANGE
DC power supply	Output voltage : 13.2 (13.6) V DC Current capacity : 15 A or more	Audio generator	Frequency range : 300–3000 Hz Measuring range : 1–500 mV
RF power meter (terminated type)	Measuring range : 1–50 W Frequency range : 300–600 MHz Impedance : 50 Ω SWR : Less than 1.2 : 1	Standard signal generator (SSG)	Frequency range : 0.1–600 MHz Output level : 0.1 μV–32 mV (–127 to –17 dBm)
Frequency counter	Frequency range : 0.1–600 MHz Frequency accuracy : ±1 ppm or better Sensitivity : 100 mV or better	Oscilloscope	Frequency range : DC–20 MHz Measuring range : 0.01–20 V
FM deviation meter	Frequency range : DC–600 MHz Measuring range : 0 to ±10 kHz	AC millivoltmeter	Measuring range : 10 mV–10 V
DC voltmeter	Input impedance : 50 kΩ/V DC or better	External speaker	Input impedance : 4 Ω Capacity : 5 W or more
		Attenuator	Power attenuation : 50 or 60 dB Capacity : 50 W or more

■ ADJUSTMENT FREQUENCY DATA

Before starting the adjustment, back up the original frequency data and program adjustment frequency at right using the optional programming software (EX-2057 Rev. 1.0 or later for IC-F410/F420, CS-F300S for IC-F410S/F420S), cloning cable (OPC-478) and adaptor cable (OPC-592) for your convenience.

■ TRIMMER ADJUSTMENT

When you adjust the contents on page 5-4, TRIMMER ADJUSTMENT, the optional EX-2057 (or CS-F300S), OPC-478 and JIG CABLE (See illustration at CONNECTIONS.) are required.

• STARTING TRIMMER ADJUSTMENT

Turn the transceiver power ON, connect a computer to the [MIC] jack using the optional OPC-478 CLONING CABLE and JIG CABLE, then start up the "ADJUST" program in EX-2057 (or CS-F300S).

• STARTING THE PROGRAM

- ① Boot up DOS.
- ② Insert the EX-2057 (CS-F300S) backup disk into drive A.
- ③ Type the following to start up the program:
ADJ>ADJUST [/A : /B]*1 [/1 : /2]*2 [Enter]
 - The adjustment screen appears after reading set data from the transceiver.
- ④ After the adjustment screen appears, set or modify the data as desired.
 - *1PLL reference crystal type.
 /A: This does not activate for IC-F410/F410S/F420/F420S's adjustment.
 /B: TCXO crystal type. (You must select [/B] for IC-F410/F410S/F420/F420S's adjustment.)
 - *2RS-232C port number.

• ADJUSTMENT FREQUENCY

Channel No.	Frequency [MHz]						Power selection
	L	P ML	L ML	MH	P H	L H	
1	400.0	440.0	450.0	470.0	490.0		Low1
2	430.0	470.0		490.0	520.0	512.0	Low1
3	400.0	440.0	450.0	470.0	490.0		Low2
4	400.0	440.0	450.0	470.0	490.0		High

[P]: IC-F410/F410S (PMR), [L]: IC-F420/F420S (LMR)
 L: L-band, ML: ML-band, MH: MH-band, H: H-band

Annotations for the screenshot:

- Boot up DOS, and change the directory.
- Startup command.
- Program starts up, then the adjustment screen appears after reading set data from the transceiver.

NOTE: When the EEPROM (FRONT unit; IC3) is replaced or the transceiver displays an error message and beeps, the following operation is necessary before starting the ADJUSTMENT.

1. Download the programmed data using the EX-2057 or CS-F300S from an exact same version of the transceiver, then save it. (See the instructions for detailed operation.)
2. Set the cursor to the [MODEL] and push the [↓] key on the computer keyboard.
3. Type "RESERVE" then push [Enter].
 "Reserved" indicator flashes at the right hand, top corner on the computer screen.
4. Connect the transceiver which has been repaired, then write the data to the transceiver.

PROGRAM SCREEN EXAMPLE

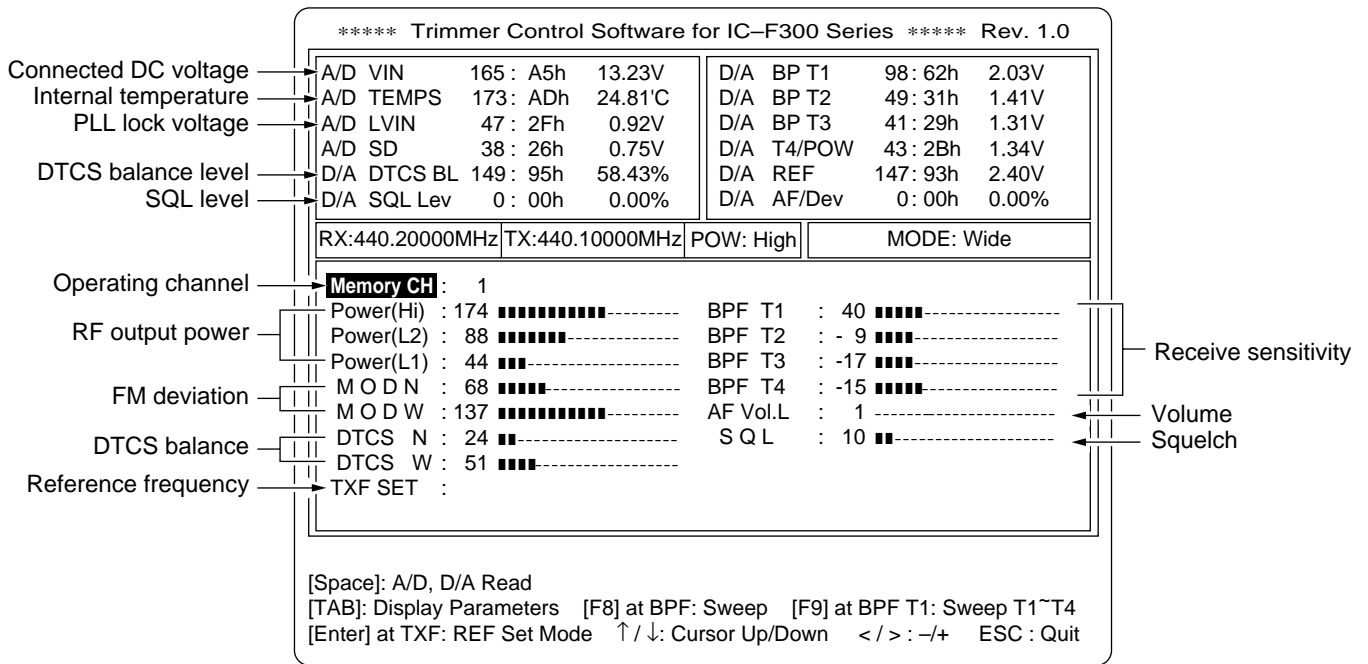

NOTE: The above values for settings are examples only. Each transceiver has its own specific values for each setting.

CONNECTIONS

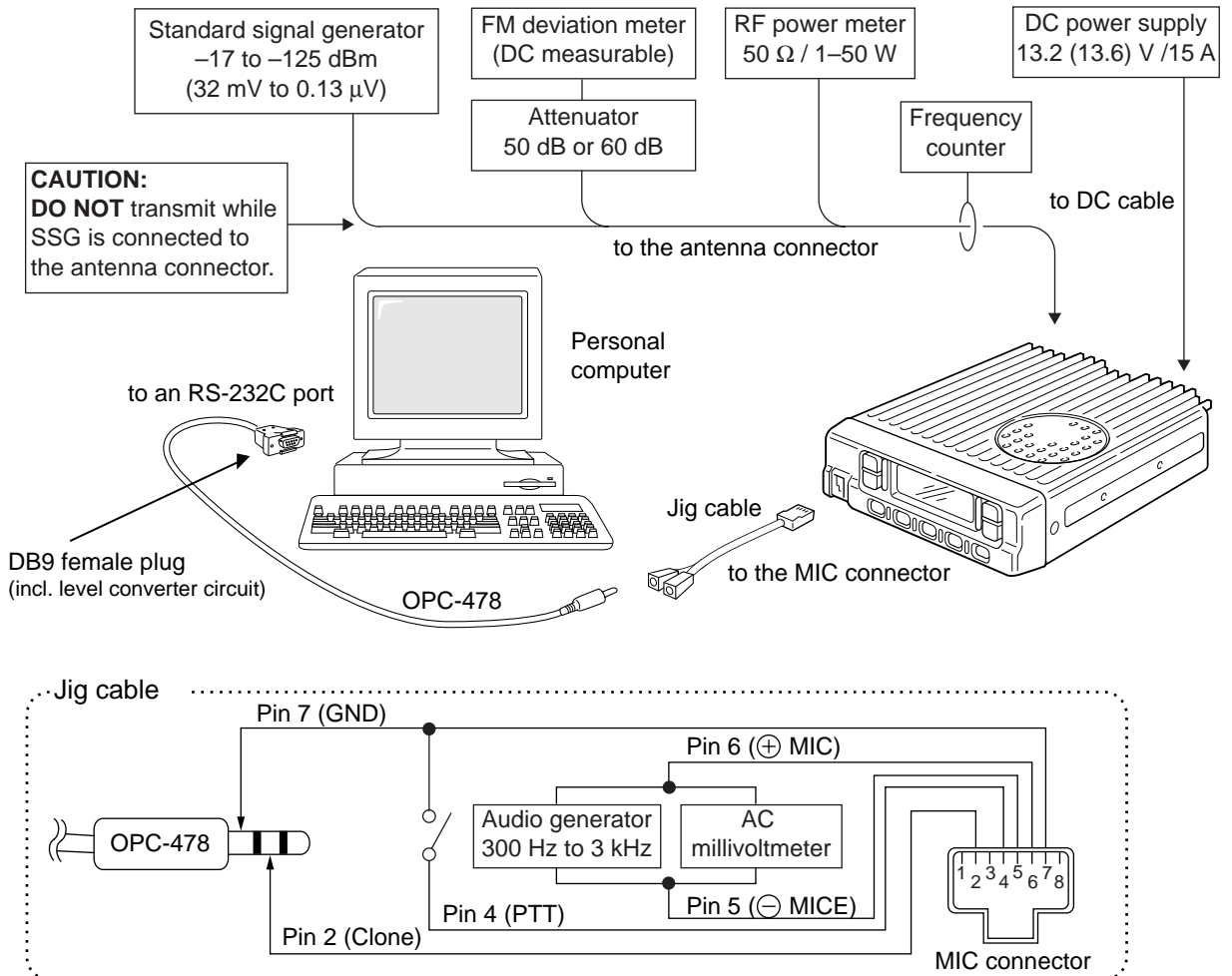

5-2 PLL ADJUSTMENT

ADJUSTMENT	ADJUSTMENT CONDITION	MEASUREMENT		VALUE	ADJUSTMENT POINT		
		UNIT	LOCATION		UNIT	ADJUST	
PLL LOCK VOLTAGE	1	<ul style="list-style-type: none"> Operating frequency: (Ch1) [L-band] : 400.00000 MHz [ML-band] P : 440.00000 MHz [ML-band] L : 450.00000 MHz [MH-band] : 470.00000 MHz [H-band] : 490.00000 MHz Receiving 	MAIN	Connect a digital multi-meter or oscilloscope to the check point CP1.	1.5 V	MAIN	L23
	2	<ul style="list-style-type: none"> Power selection : Low1 Transmitting 				1.5 V	L26
	3	<ul style="list-style-type: none"> Operating frequency: (Ch2) [L-band] : 430.00000 MHz [ML-band] : 470.00000 MHz [MH-band] : 490.00000 MHz [H-band] P : 520.00000 MHz [H-band] L : 512.00000 MHz Receiving 				3.5–5.5 V	Verify
	4	<ul style="list-style-type: none"> Power selection : Low1 Transmitting 					

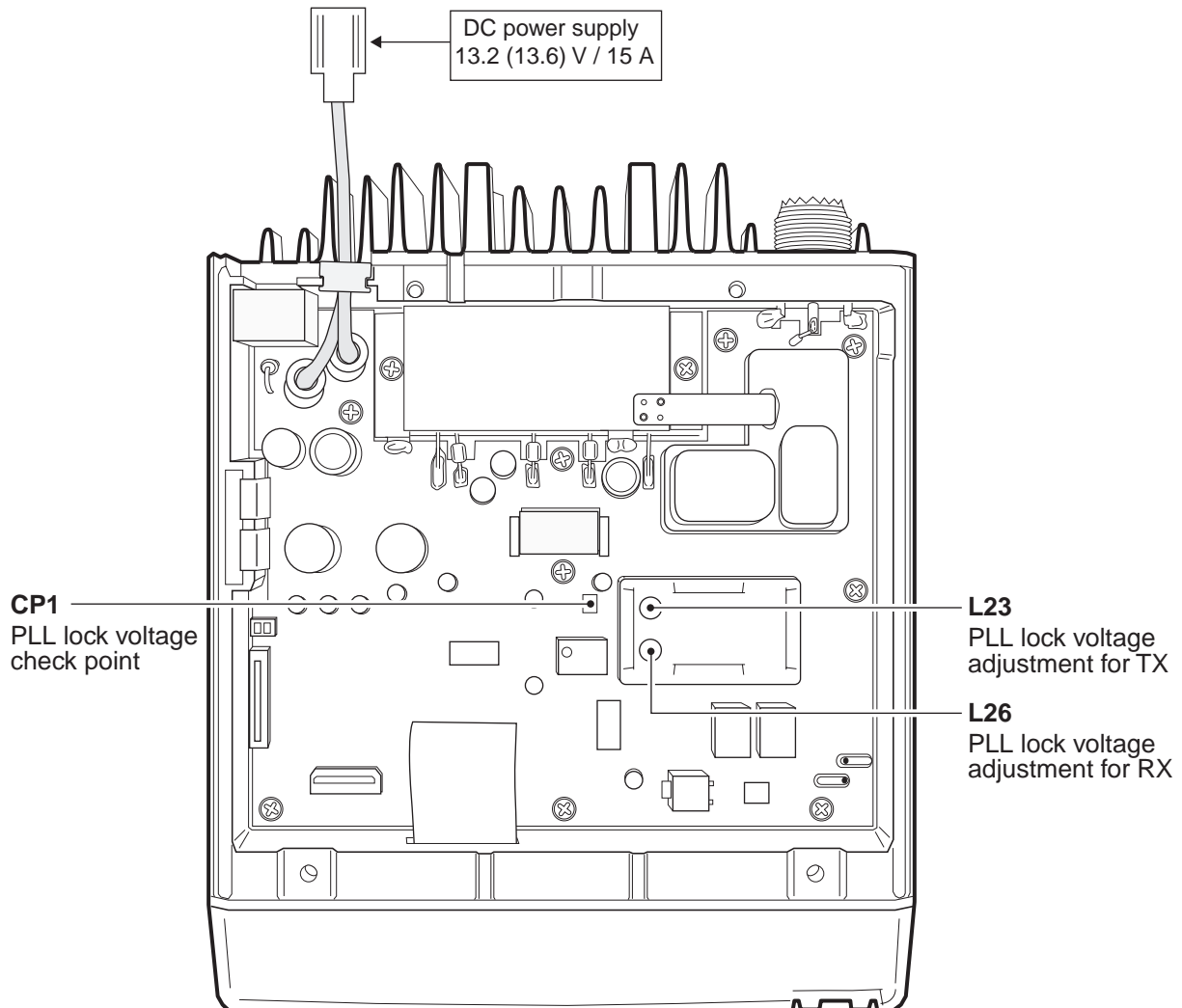

5-3 TRIMMER ADJUSTMENT

Select an operation using [↑] / [↓] keys, then set specified value using [←] / [→] keys on the connected computer keyboard.

ADJUSTMENT	ADJUSTMENT CONDITION	MEASUREMENT		VALUE	
		UNIT	LOCATION		
REFERENCE FREQUENCY [TXF SET]	1 <ul style="list-style-type: none"> Operating frequency: (Ch2) <ul style="list-style-type: none"> [L-band] : 430.00000 MHz [ML-band] : 470.00000 MHz [MH-band] : 490.00000 MHz [H-band] <input type="checkbox"/> : 520.00000 MHz [H-band] <input type="checkbox"/> : 512.00000 MHz Power selection : Low1 Transmitting 	Rear panel	Loosely couple a frequency counter to the antenna connector.	430.00000 MHz [L-band]	
	2 <ul style="list-style-type: none"> Transmitting 			470.00000 MHz [ML-band]	
OUTPUT POWER [Power (Hi)]	1 <ul style="list-style-type: none"> Operating frequency: (Ch4) <ul style="list-style-type: none"> [L-band] : 400.00000 MHz [ML-band] <input type="checkbox"/> : 440.00000 MHz [ML-band] <input type="checkbox"/> : 450.00000 MHz [MH-band] : 470.00000 MHz [H-band] : 490.00000 MHz Power selection : High Transmitting 	Rear panel	Connect an RF power meter to the antenna connector.	35.0 W [LMR]	
	[Power (L2)]			2 <ul style="list-style-type: none"> Power selection : Low2 (Ch3) Transmitting 	25.0 W [PMR]
	[Power (L1)]			3 <ul style="list-style-type: none"> Power selection : Low1 (Ch1) Transmitting 	10.0 W [Italy]
FM DEVIATION [MOD N] or [MOD W]	1 <ul style="list-style-type: none"> Operating frequency: (CH1) <ul style="list-style-type: none"> [L-band] : 400.00000 MHz [ML-band] <input type="checkbox"/> : 440.00000 MHz [ML-band] <input type="checkbox"/> : 450.00000 MHz [MH-band] : 470.00000 MHz [H-band] : 490.00000 MHz Power selection : Low1 Connect an audio generator to the [MIC] jack and set as: <ul style="list-style-type: none"> 1 kHz / 40 mV Set an FM deviation meter as: <ul style="list-style-type: none"> HPF : OFF LPF : 20 kHz De-emphasis : OFF Detector : (P-P)/2 Transmitting 	Rear panel	Connect an FM deviation meter to the antenna connector through an attenuator.	±4.2 kHz (Wide)	
					±2.1 kHz (Narrow)
				NOTE: [Wide/Narrow] version must adjust both setting.	

TRIMMER ADJUSTMENT — continued

Select an operation using [↑] / [↓] keys, then set specified value using [←] / [→] keys on the connected computer keyboard.

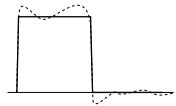
ADJUSTMENT	ADJUSTMENT CONDITION	MEASUREMENT		VALUE
		UNIT	LOCATION	
DTCS WAVE FORM	1 <ul style="list-style-type: none"> • Operating frequency: (CH1) <ul style="list-style-type: none"> [L-band] : 400.00000 MHz [ML-band] P : 440.00000 MHz [ML-band] L : 450.00000 MHz [MH-band] : 470.00000 MHz [H-band] : 490.00000 MHz • Power selection : Low1 • No audio signal is applied to the [MIC] jack • DTCS code : 007 • Set an FM deviation meter as: <ul style="list-style-type: none"> HPF : OFF LPF : 20 kHz De-emphasis : OFF Detector : (P-P)/2 • Transmitting 	Rear panel	Connect an FM deviation meter with an oscilloscope to the antenna connector through an attenuator.	Set to flat wave form 
RECEIVE [BPF T1]– [BPF T4]	<ul style="list-style-type: none"> • Operating frequency: (CH1) <ul style="list-style-type: none"> [L-band] : 400.00000 MHz [ML-band] P : 440.00000 MHz [ML-band] L : 450.00000 MHz [MH-band] : 470.00000 MHz [H-band] : 490.00000 MHz • Connect a standard signal generator to the antenna connector and set as: <ul style="list-style-type: none"> Level : 3.2 μV* (–97 dBm) Modulation: 1 kHz Deviation : ±3.5 kHz (Wide) ±1.75 kHz (Narrow) • Receiving <p>CONVENIENT: The BPF T1–BPF T4 can be adjusted automatically.</p> <p>①-1 Set each to 0, then push the [F9] key. (The cursor must be set to the BPF T1 position.)</p> <p>①-2 The connected PC tunes BPF T1–BPF T4 to peak levels. or</p> <p>②-1 Set the cursor to one of BPF T1, T2, T3 or T4 as desired.</p> <p>②-2 Push [F8] to start tuning.</p> <p>②-3 Repeat ②-1 and ②-2 to perform additional BPF tuning.</p>	Rear panel	Connect a SINAD meter with a 4 Ω load to the external [SP] jack.	Minimum distortion level
SQUELCH LEVEL [SQL]	1 <ul style="list-style-type: none"> • Operating frequency: (CH1) <ul style="list-style-type: none"> [L-band] : 400.00000 MHz [ML-band] P : 440.00000 MHz [ML-band] L : 450.00000 MHz [MH-band] : 470.00000 MHz [H-band] : 490.00000 MHz • Connect an SSG to the antenna connector and set as : <ul style="list-style-type: none"> Level : adjust SSG's level to 8 dB SINAD on the connecting SINAD meter Modulation: OFF • Receiving 	Rear panel	Connect a SINAD meter with a 4 Ω load to the external [SP] jack.	At the point where noise just appears.

*This output level of a standard signal generator (SSG) is indicated as SSG's open circuit.

5-4 BEEP ADJUSTMENT

ADJUSTMENT	ADJUSTMENT CONDITION	MEASUREMENT		VALUE	ADJUSTMENT POINT	
		UNIT	LOCATION		UNIT	ADJUST
BEEP AUDIO 1	<ul style="list-style-type: none"> • Operating frequency: Any • Connect an audio generator to pin 25 (MAIN unit; J2) and set as: 1 kHz / 550 mV • Squelch : OPEN • Volume level: 1 • Receiving 	Rear panel	Connect an AC millivoltmeter with 4 Ω load to the [SP] jack.	62.5 mV	FRONT	R60

• MAIN unit

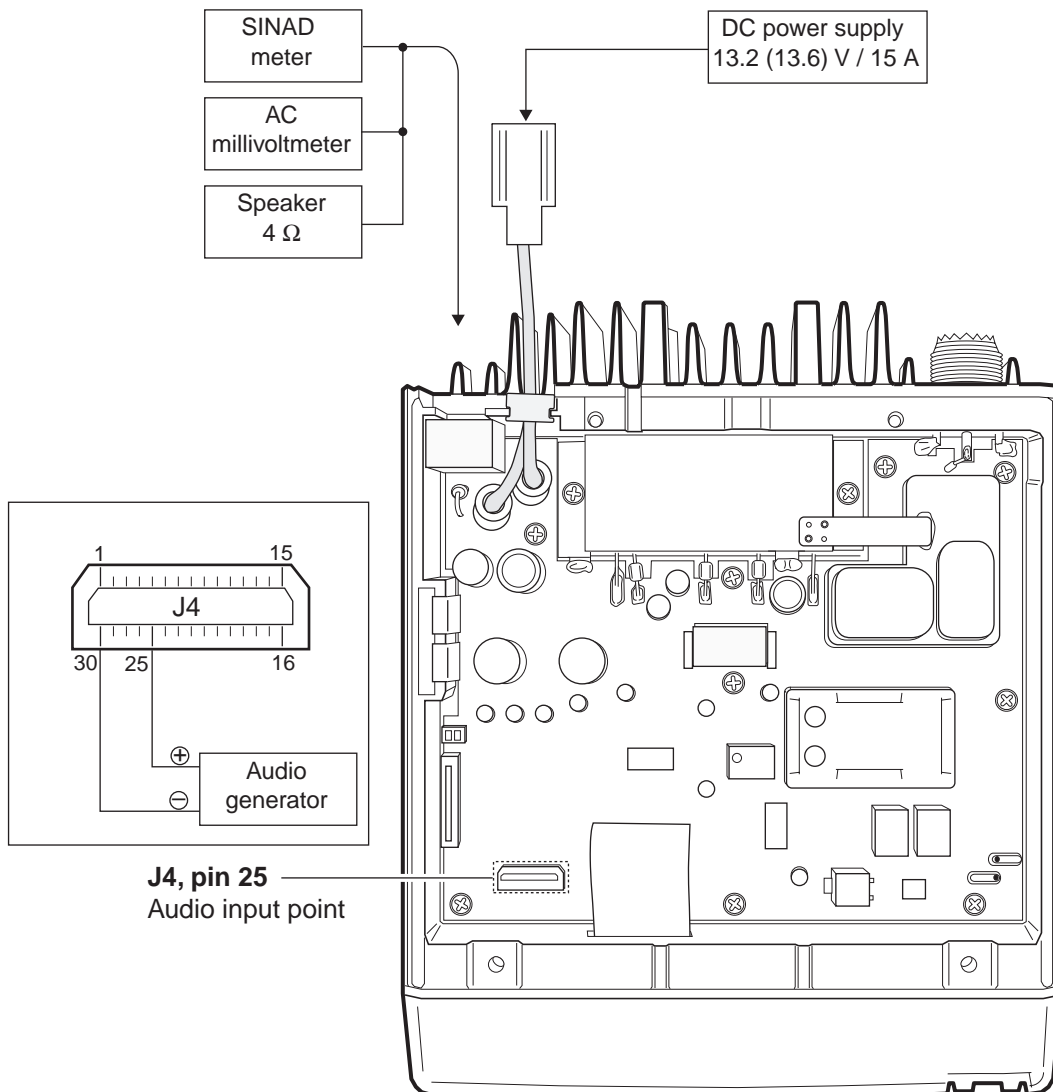

• FRONT unit

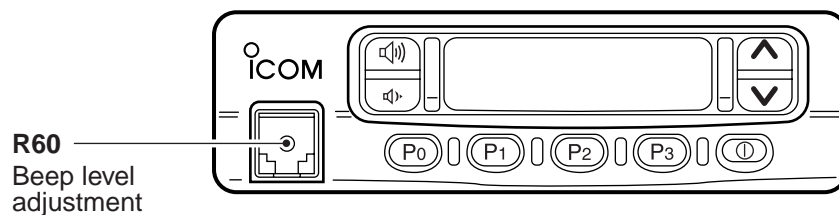

SECTION 6 PARTS LIST

[FRONT UNIT]

REF NO.	ORDER NO.	DESCRIPTION	
IC1	1140007911	S.IC	HD6433875B20H
IC2	1110003500	S.IC	S-80742SL-A6-T1
IC3	1130008670	S.IC	25LC160T-I/SN
Q1	1530002060	S.TRANSISTOR	2SC4081 T107 R
Q3	1590000440	S.TRANSISTOR	DTA143ZUA T106
	1530002060	S.TRANSISTOR	2SC4081 T107 R
Q4	1590000660	S.TRANSISTOR	DTC144TU T107
Q5	1590001650	S.TRANSISTOR	XP4601 (TX)
Q6	1530002060	S.TRANSISTOR	2SC4081 T107 R
Q7	1530002060	S.TRANSISTOR	2SC4081 T107 R
Q10	1590000660	S.TRANSISTOR	DTC144TU T107
Q11	1530002060	S.TRANSISTOR	2SC4081 T107 R
Q12	1530002060	S.TRANSISTOR	2SC4081 T107 R
Q13	1530002060	S.TRANSISTOR	2SC4081 T107 R
Q14	1530002060	S.TRANSISTOR	2SC4081 T107 R
Q15	1530002060	S.TRANSISTOR	2SC4081 T107 R
Q16	1530002060	S.TRANSISTOR	2SC4081 T107 R
Q17	1530002060	S.TRANSISTOR	2SC4081 T107 R
Q18	1590000430	S.TRANSISTOR	DTC144EUA T106
Q19	1590000430	S.TRANSISTOR	DTC144EUA T106
D1	1790001280	S.DIODE	MA111 (TX)
D2	1750000130	S.DIODE	DA204U T107
D3	1750000130	S.DIODE	DA204U T107
D4	1750000130	S.DIODE	DA204U T107
D5	1790000620	S.DIODE	MA77 (TX)
D6	1730002320	S.ZENER	MA8051-M (TX)
X1	6050010150	S.XTAL	CR-590 (6.8015 MHz)
L1	6200001720	S.COIL	NL 322522T-1R0J
L3	6200003190	S.COIL	NL 322522T-470J
R1	7030003560	S.RESISTOR	ERJ3GEYJ 103 V (10 kΩ)
R2	7030003680	S.RESISTOR	ERJ3GEYJ 104 V (100 kΩ)
R3	7030003720	S.RESISTOR	ERJ3GEYJ 224 V (220 kΩ)
R4	7030003680	S.RESISTOR	ERJ3GEYJ 104 V (100 kΩ)
R5	7030003570	S.RESISTOR	ERJ3GEYJ 123 V (12 kΩ)
R6	7030003570	S.RESISTOR	ERJ3GEYJ 123 V (12 kΩ)
R7	7030003800	S.RESISTOR	ERJ3GEYJ 105 V (1 MΩ)
R8	7030003200	S.RESISTOR	ERJ3GEYJ 100 V (10 Ω)
R11	7030003430	S.RESISTOR	ERJ3GEYJ 821 V (820 Ω)
R12	7030003390	S.RESISTOR	ERJ3GEYJ 391 V (390 Ω)
R14	7030003390	S.RESISTOR	ERJ3GEYJ 391 V (390 Ω)
R15	7030003480	S.RESISTOR	ERJ3GEYJ 222 V (2.2 kΩ)
R16	7030003480	S.RESISTOR	ERJ3GEYJ 222 V (2.2 kΩ)
R17	7410000950	S.ARRAY	EXB-V8V 102JV
R18	7030003400	S.RESISTOR	ERJ3GEYJ 471 V (470 Ω)
R19	7030003400	S.RESISTOR	ERJ3GEYJ 471 V (470 Ω)
R20	7030003440	S.RESISTOR	ERJ3GEYJ 102 V (1 kΩ)
R21	7030003440	S.RESISTOR	ERJ3GEYJ 102 V (1 kΩ)
R22	7030003200	S.RESISTOR	ERJ3GEYJ 100 V (10 Ω)
R24	7030003710	S.RESISTOR	ERJ3GEYJ 184 V (180 kΩ)
R25	7030003650	S.RESISTOR	ERJ3GEYJ 563 V (56 kΩ)
R26	7030003510	S.RESISTOR	ERJ3GEYJ 392 V (3.9 kΩ)
R27	7030003630	S.RESISTOR	ERJ3GEYJ 393 V (39 kΩ)
R28	7030003440	S.RESISTOR	ERJ3GEYJ 102 V (1 kΩ)
R29	7030003440	S.RESISTOR	ERJ3GEYJ 102 V (1 kΩ)
R30	7030003560	S.RESISTOR	ERJ3GEYJ 103 V (10 kΩ)
R31	7030003560	S.RESISTOR	ERJ3GEYJ 103 V (10 kΩ)
R32	7030003600	S.RESISTOR	ERJ3GEYJ 223 V (22 kΩ)
R33	7030003660	S.RESISTOR	ERJ3GEYJ 683 V (68 kΩ)
R34	7030003610	S.RESISTOR	ERJ3GEYJ 273 V (27 kΩ)
R35	7030003560	S.RESISTOR	ERJ3GEYJ 103 V (10 kΩ)
R36	7030003570	S.RESISTOR	ERJ3GEYJ 123 V (12 kΩ)
R37	7030003570	S.RESISTOR	ERJ3GEYJ 123 V (12 kΩ)
R38	7030003640	S.RESISTOR	ERJ3GEYJ 473 V (47 kΩ)
R39	7030003680	S.RESISTOR	ERJ3GEYJ 104 V (100 kΩ)
R40	7030003680	S.RESISTOR	ERJ3GEYJ 104 V (100 kΩ)
R41	7030003730	S.RESISTOR	ERJ3GEYJ 274 V (270 kΩ)

[FRONT UNIT]

REF NO.	ORDER NO.	DESCRIPTION	
R42	7030003740	S.RESISTOR	ERJ3GEYJ 334 V (330 kΩ)
R43	7030003570	S.RESISTOR	ERJ3GEYJ 123 V (12 kΩ)
R44	7410000950	S.ARRAY	EXB-V8V 102JV
R45	7410000950	S.ARRAY	EXB-V8V 102JV
R46	7410000950	S.ARRAY	EXB-V8V 102JV
R47	7410000950	S.ARRAY	EXB-V8V 102JV
R48	7410000950	S.ARRAY	EXB-V8V 102JV
R49	7030003320	S.RESISTOR	ERJ3GEYJ 101 V (100 Ω)
R50	7030003680	S.RESISTOR	ERJ3GEYJ 104 V (100 kΩ)
R51	7030003440	S.RESISTOR	ERJ3GEYJ 102 V (1 kΩ)
R52	7030003440	S.RESISTOR	ERJ3GEYJ 102 V (1 kΩ)
R53	7030003440	S.RESISTOR	ERJ3GEYJ 102 V (1 kΩ)
R54	7030003440	S.RESISTOR	ERJ3GEYJ 102 V (1 kΩ)
R55	7030003680	S.RESISTOR	ERJ3GEYJ 104 V (100 kΩ)
R56	7030003530	S.RESISTOR	ERJ3GEYJ 562 V (5.6 kΩ)
R57	7030003580	S.RESISTOR	ERJ3GEYJ 153 V (15 kΩ)
R58	7030003640	S.RESISTOR	ERJ3GEYJ 473 V (47 kΩ)
R59	7030003440	S.RESISTOR	ERJ3GEYJ 102 V (1 kΩ)
R60	7310002740	S.TRIMMER	RV-150 (RH03A3A14X0FC)103
R61	7030003680	S.RESISTOR	ERJ3GEYJ 104 V (100 kΩ)
R62	7030003440	S.RESISTOR	ERJ3GEYJ 102 V (1 kΩ)
R63	7030003440	S.RESISTOR	ERJ3GEYJ 102 V (1 kΩ)
R64	7030003440	S.RESISTOR	ERJ3GEYJ 102 V (1 kΩ)
R65	7030003680	S.RESISTOR	ERJ3GEYJ 104 V (100 kΩ)
R66	7030003680	S.RESISTOR	ERJ3GEYJ 104 V (100 kΩ)
R67	7030003680	S.RESISTOR	ERJ3GEYJ 104 V (100 kΩ)
R68	7030003640	S.RESISTOR	ERJ3GEYJ 473 V (47 kΩ)
R69	7030003680	S.RESISTOR	ERJ3GEYJ 104 V (100 kΩ)
R70	7030003640	S.RESISTOR	ERJ3GEYJ 473 V (47 kΩ)
R71	7030003440	S.RESISTOR	ERJ3GEYJ 102 V (1 kΩ)
R72	7030003400	S.RESISTOR	ERJ3GEYJ 471 V (470 Ω)
R73	7030003470	S.RESISTOR	ERJ3GEYJ 182 V (1.8 kΩ)
R74	7030003470	S.RESISTOR	ERJ3GEYJ 182 V (1.8 kΩ)
R75	7030003470	S.RESISTOR	ERJ3GEYJ 182 V (1.8 kΩ)
R76	7030003470	S.RESISTOR	ERJ3GEYJ 182 V (1.8 kΩ)
R77	7030003470	S.RESISTOR	ERJ3GEYJ 182 V (1.8 kΩ)
R78	7030003650	S.RESISTOR	ERJ3GEYJ 563 V (56 kΩ)
R79	7030003630	S.RESISTOR	ERJ3GEYJ 393 V (39 kΩ)
R80	7030003680	S.RESISTOR	ERJ3GEYJ 104 V (100 kΩ)
R81	7030003680	S.RESISTOR	ERJ3GEYJ 104 V (100 kΩ)
R82	7030003680	S.RESISTOR	ERJ3GEYJ 104 V (100 kΩ)
R83	7030003680	S.RESISTOR	ERJ3GEYJ 104 V (100 kΩ)
R84	7030003680	S.RESISTOR	ERJ3GEYJ 104 V (100 kΩ)
R85	7030003440	S.RESISTOR	ERJ3GEYJ 102 V (1 kΩ)
R86	7030003440	S.RESISTOR	ERJ3GEYJ 102 V (1 kΩ)
R87	7030003430	S.RESISTOR	ERJ3GEYJ 821 V (820 Ω)
C1	4030006900	S.CERAMIC	C1608 JB 1E 103K-T-A
C2	4030006900	S.CERAMIC	C1608 JB 1E 103K-T-A
C3	4030006900	S.CERAMIC	C1608 JB 1E 103K-T-A
C4	4030006900	S.CERAMIC	C1608 JB 1E 103K-T-A
C5	4030006900	S.CERAMIC	C1608 JB 1E 103K-T-A
C6	4030006900	S.CERAMIC	C1608 JB 1H 103K-T-A
C7	4030006900	S.CERAMIC	C1608 JB 1E 103K-T-A
C8	4030006900	S.CERAMIC	C1608 JB 1E 103K-T-A
C9	4550006200	S.TANTALUM	ECST0JY106R
C10	4030006900	S.CERAMIC	C1608 JB 1E 103K-T-A
C11	4030006860	S.CERAMIC	C1608 JB 1H 102K-T-A
C12	4030006900	S.CERAMIC	C1608 JB 1E 103K-T-A
C13	4030006860	S.CERAMIC	C1608 JB 1H 102K-T-A
C14	4550006140	S.TANTALUM	ECST1EY474R
C15	4030006860	S.CERAMIC	C1608 JB 1H 102K-T-A
C16	4030006860	S.CERAMIC	C1608 JB 1H 102K-T-A
C17	4030006860	S.CERAMIC	C1608 JB 1H 102K-T-A
C18	4030007090	S.CERAMIC	C1608 CH 1H 470J-T-A
C19	4030009920	S.CERAMIC	C1608 CH 1H 050B-T-A
C20	4030009990	S.CERAMIC	C1608 CH 1H 200J-T-A

©: LCD type (F410/F420), Ⓜ: LED type (F410S/F420S)

S.=Surface mount

[FRONT UNIT]

REF NO.	ORDER NO.	DESCRIPTION	
C21	4030006900	S.CERAMIC	C1608 JB 1E 103K-T-A
C22	4030007090	S.CERAMIC	C1608 CH 1H 470J-T-A
C23	4030007090	S.CERAMIC	C1608 CH 1H 470J-T-A
C24	4030007090	S.CERAMIC	C1608 CH 1H 470J-T-A
C25	4030007090	S.CERAMIC	C1608 CH 1H 470J-T-A
C26	4030007090	S.CERAMIC	C1608 CH 1H 470J-T-A
C27	4030007090	S.CERAMIC	C1608 CH 1H 470J-T-A
C28	4030006860	S.CERAMIC	C1608 JB 1H 102K-T-A
C29	4030006860	S.CERAMIC	C1608 JB 1H 102K-T-A
C30	4030006850	S.CERAMIC	C1608 JB 1H 471K-T-A
C32	4030006860	S.CERAMIC	C1608 JB 1H 102K-T-A
C33	4030006860	S.CERAMIC	C1608 JB 1H 102K-T-A
C34	4030007090	S.CERAMIC	C1608 CH 1H 470J-T-A
C35	4030006860	S.CERAMIC	C1608 JB 1H 102K-T-A
C36	4030006900	S.CERAMIC	C1608 JB 1E 103K-T-A
C37	4550006700	S.TANTALUM	ECST1AY106R
C38	4030008880	S.CERAMIC	C1608 JB 1C 223K-T-A
C39	4030011600	S.CERAMIC	C1608 JB 1C 104KT-N
C40	4030008920	S.CERAMIC	C1608 JB 1C 473K-T-A
C41	4030008900	S.CERAMIC	C1608 JB 1C 333K-T-A
C42	4030011600	S.CERAMIC	C1608 JB 1C 104KT-N
C43	4030006900	S.CERAMIC	C1608 JB 1E 103K-T-A
C44	4030006900	S.CERAMIC	C1608 JB 1E 103K-T-A
C45	4030006900	S.CERAMIC	C1608 JB 1E 103K-T-A
C46	4030007090	S.CERAMIC	C1608 CH 1H 470J-T-A
C47	4030007090	S.CERAMIC	C1608 CH 1H 470J-T-A
C48	4030007090	S.CERAMIC	C1608 CH 1H 470J-T-A
C49	4030007090	S.CERAMIC	C1608 CH 1H 470J-T-A
C50	4030007090	S.CERAMIC	C1608 CH 1H 470J-T-A
C52	4030007090	S.CERAMIC	C1608 CH 1H 470J-T-A
C56	4030007090	S.CERAMIC	C1608 CH 1H 470J-T-A
C57	4030007090	S.CERAMIC	C1608 CH 1H 470J-T-A
C58	4030007090	S.CERAMIC	C1608 CH 1H 470J-T-A
C59	4030007090	S.CERAMIC	C1608 CH 1H 470J-T-A
C60	4030007090	S.CERAMIC	C1608 CH 1H 470J-T-A
C61	4030007090	S.CERAMIC	C1608 CH 1H 470J-T-A
C62	4030007090	S.CERAMIC	C1608 CH 1H 470J-T-A
C63	4030007090	S.CERAMIC	C1608 CH 1H 470J-T-A
C64	4030007090	S.CERAMIC	C1608 CH 1H 470J-T-A
C65	4030007090	S.CERAMIC	C1608 CH 1H 470J-T-A
C66	4030007090	S.CERAMIC	C1608 CH 1H 470J-T-A
C67	4030006860	S.CERAMIC	C1608 JB 1H 102K-T-A
C69	4030006860	S.CERAMIC	C1608 JB 1H 102K-T-A
C70	4030007090	S.CERAMIC	C1608 CH 1H 470J-T-A
C71	4030007090	S.CERAMIC	C1608 CH 1H 470J-T-A
C73	4030007090	S.CERAMIC	C1608 CH 1H 470J-T-A
C74	4030007090	S.CERAMIC	C1608 CH 1H 470J-T-A
C77	4030007090	S.CERAMIC	C1608 CH 1H 470J-T-A
C78	4030007090	S.CERAMIC	C1608 CH 1H 470J-T-A
C79	4030007090	S.CERAMIC	C1608 CH 1H 470J-T-A
C80	4030007090	S.CERAMIC	C1608 CH 1H 470J-T-A
C82	4030011600	S.CERAMIC	C1608 JB 1C 104KT-N
C83	4030006860	S.CERAMIC	C1608 JB 1H 102K-T-A
C84	4030006860	S.CERAMIC	C1608 JB 1H 102K-T-A
C85	4030006860	S.CERAMIC	C1608 JB 1H 102K-T-A
C86	4030006860	S.CERAMIC	C1608 JB 1H 102K-T-A
C87	4030006860	S.CERAMIC	C1608 JB 1H 102K-T-A
C88	4030006860	S.CERAMIC	C1608 JB 1H 102K-T-A
C89	4030006860	S.CERAMIC	C1608 JB 1H 102K-T-A
C90	4030006860	S.CERAMIC	C1608 JB 1H 102K-T-A
C92	4030007090	S.CERAMIC	C1608 CH 1H 470J-T-A
J1	6450001470	CONNECTOR	95003-2881
J2	6510020510	S.CONNECTOR	FH12-40S-0.5SV
DS1	5030001540	LCD	LD-HU10140J
DS2	5040002310	S.LED	SML-311YTT86
DS3	5040002310	S.LED	SML-311YTT86
DS4	5040002310	S.LED	SML-311YTT86
DS5	5040002310	S.LED	SML-311YTT86
DS6	5040002310	S.LED	SML-311YTT86
DS7	5040002310	S.LED	SML-311YTT86
DS8	5040002310	S.LED	SML-311YTT86
DS9	5040002310	S.LED	SML-311YTT86
DS10	5040002310	S.LED	SML-311YTT86
DS11	5040002310	S.LED	SML-311YTT86
DS12	5040001760	S.LED	SEC 2422C
DS13	5040002310	S.LED	SML-311YTT86
DS14	5040002310	S.LED	SML-311YTT86
DS15	5040002310	S.LED	SML-311YTT86
DS16	5040002310	S.LED	SML-311YTT86
DS17	5040002310	S.LED	SML-311YTT86

Ⓢ: LCD type (F410/F420), Ⓡ: LED type (F410S/F420S)

[FRONT UNIT]

REF NO.	ORDER NO.	DESCRIPTION	
W1	7030000010	S.JUMPER	MCR10EZHZ JPW (000)
W2	7030003860	S.JUMPER	ERJ3GE JPW V
W3	8900007680	CABLE	OPC-741
EP1	0910049322	PCB	B 5042B
	0910051231	PCB	B 5289A
EP2	8930044930	LCD CONTACT	SRCN-2055-SP-N-W

S.=Surface mount

[MAIN UNIT]

REF NO.	ORDER NO.	DESCRIPTION	
IC1	1110003490	S.IC	TA31136FN (D,EL)
IC2	1180001250	S.IC	TA7808F (TE16L)
IC3	1180000970	S.IC	AN78L05M-(E1)
IC4	1110002700	S.IC	NJM2904M-T1
IC5	1150001670	IC	S-AU27AL/SC-1322 [P] [L-band]
	1150001680	IC	S-AU27AM/SC-1323 [P] [ML/[MH-band]
	1150001690	IC	S-AU27AH/SC-1324 [P] [H-band]
	1150001250	IC	M57788L/SC1236 [L] [L-band]
	1150001260	IC	M57788H/SC1237 [L] [ML-band]
	1150001700	IC	M57788UH/SC1325 [L] [MH-band]
	1150001710	IC	M57788SH/SC1326 [L] [H-band]
IC6	1110002680	S.IC	NJM2902M-T1
IC7	1110002700	S.IC	NJM2904M-T1
IC8	1110002700	S.IC	NJM2904M-T1
IC9	1110003090	IC	LA4425A
IC10	1130007610	S.IC	μPD3140GS-E1 (DS8)
IC11	1130007690	S.IC	BU4066BCF-T1
IC12	1190000350	S.IC	M62363FP-650C
IC13	1130007700	S.IC	BU4094BCF-T1
Q1	1590000720	S.TRANSISTOR	DTA144EUA T106
Q2	1580000660	S.FET	3SK272-(TX)
Q3	1580000680	S.FET	3SK241-R (TX)
Q4	1530002600	S.TRANSISTOR	2SC4215-O (TE85R)
Q5	1530002060	S.TRANSISTOR	2SC4081 T107 R
Q7	1590000720	S.TRANSISTOR	DTA144EUA T106
Q8	1540000550	S.TRANSISTOR	2SD1664 T100Q
Q9	1590000680	S.TRANSISTOR	DTC114EUA T106
Q10	1540000550	S.TRANSISTOR	2SD1664 T100Q
Q11	1590000680	S.TRANSISTOR	DTC114EUA T106
Q12	1520000460	S.TRANSISTOR	2SB1132 T100 R
Q13	1590001190	S.TRANSISTOR	XP6501-(TX) .AB
Q14	1550000020	S.FET	2SJ377 (TE16R)
Q15	1590000680	S.TRANSISTOR	DTC114EUA T106
Q16	1590000430	S.TRANSISTOR	DTC144EUA T106
Q17	1530002060	S.TRANSISTOR	2SC4081 T107 R
Q18	1520000380	TRANSISTOR	2SB1143 S
Q19	1530003291	S.TRANSISTOR	2SC4703-T1 SE
Q20	1530003310	S.TRANSISTOR	2SC5107-O (TE85R)
Q21	1530003310	S.TRANSISTOR	2SC5107-O (TE85R)
Q22	1530002060	S.TRANSISTOR	2SC4081 T107 R
Q23	1530003420	S.TRANSISTOR	2SC5110-O (TE85R)
Q24	1590000680	S.TRANSISTOR	DTC114EUA T106
Q25	1530003420	S.TRANSISTOR	2SC5110-O (TE85R)
Q26	1590000680	S.TRANSISTOR	DTC114EUA T106
Q27	1590000430	S.TRANSISTOR	DTC144EUA T106
Q28	1530003310	S.TRANSISTOR	2SC5107-O (TE85R)
Q29	1530003310	S.TRANSISTOR	2SC5107-O (TE85R)
Q30	1530003420	S.TRANSISTOR	2SC5110-O (TE85R)
Q31	1530002060	S.TRANSISTOR	2SC4081 T107 R
Q32	1590000430	S.TRANSISTOR	DTC144EUA T106
Q33	1560000530	S.FET	2SK880-GR (TE85R)
Q34	1560000400	S.FET	2SK536-TA
Q35	1530002060	S.TRANSISTOR	2SC4081 T107 R
Q36	1590000430	S.TRANSISTOR	DTC144EUA T106
Q37	1590000430	S.TRANSISTOR	DTC144EUA T106
Q38	1590000430	S.TRANSISTOR	DTC144EUA T106
Q39	1590000430	S.TRANSISTOR	DTC144EUA T106
Q40	1590001450	S.FET	2SJ144-GR (TE85R)
Q41	1590000990	S.TRANSISTOR	DTC363EK T147
Q42	1590000430	S.TRANSISTOR	DTC144EUA T106
Q44	1590000430	S.TRANSISTOR	DTC144EUA T106
Q45	1590000720	S.TRANSISTOR	DTA144EUA T106
Q46	1590000720	S.TRANSISTOR	DTA144EUA T106
D1	1790000650	S.DIODE	MA713 (TX)
D3	1750000510	S.DIODE	UM9401F [P]
	1710000310	DIODE	MI407 [L]
D4	1710000730	S.DIODE	M1809-T11
D5	1790000620	S.DIODE	MA77 (TX)
D6	1750000260	S.DIODE	1SS352 (TPH3)
D7	1720000370	S.VARICAP	HVU350TRF
D8	1720000370	S.VARICAP	HVU350TRF
D9	1720000370	S.VARICAP	HVU350TRF
D10	1720000370	S.VARICAP	HVU350TRF
D12	1160000060	S.DIODE	DAN202U T107
D13	1160000060	S.DIODE	DAN202U T107
D14	1750000300	S.DIODE	1SS302 (TE85R)
D15	1750000300	S.DIODE	1SS302 (TE85R)

[MAIN UNIT]

REF NO.	ORDER NO.	DESCRIPTION	
D16	1790000700	DIODE	DSA3A1
D17	1750000370	S.DIODE	DA221 TL
D18	1790000620	S.DIODE	MA77 (TX)
D19	1790000620	S.DIODE	MA77 (TX)
D20	1720000370	S.VARICAP	HVU350TRF
D21	1720000520	S.VARICAP	1T365-01-T8A
D22	1720000370	S.VARICAP	HVU350TRF
D23	1790001280	S.DIODE	MA111 (TX)
D24	1160000060	S.DIODE	DAN202U T107
D25	1790001280	S.DIODE	MA111 (TX)
D27	1790001280	S.DIODE	MA111 (TX)
D28	1730000520	ZENER	RD20E B2
D29	1160000060	S.DIODE	DAN202U T107
D30	1790001280	S.DIODE	MA111 (TX)
D31	1160000060	S.DIODE	DAN202U T107
D32	1790001280	S.DIODE	MA111 (TX)
D33	1720000370	S.VARICAP	HVU350TRF
D34	1720000370	S.VARICAP	HVU350TRF
F11	2010002230	XTAL	FL-287 (46.350 MHz)
F12	2020001270	CERAMIC	CFWM450E
F13	2020001410	CERAMIC	CFWM450G
X1	6070000210	S.DISCRIMINATOR	CDBCA450CX24
X2	6050010230	S.XTAL	CR-601 (15.300 MHz)
L1	6110002110	COIL	LA-382 [H-band]
	6110001520	COIL	LA-232 other
L2	6110002110	COIL	LA-382 [H-band]
	6110001520	COIL	LA-232 other
L3	6110002110	COIL	LA-382
L4	6200005800	S.COIL	33CS-Y655LY-02M=P3 [H-band]
	6200005780	S.COIL	33CS-Y655LY-03K=P3 other
L5	6200005780	S.COIL	33CS-Y655LY-03K=P3
L6	6170000230	COIL	LW-25
L7	6200002330	S.COIL	LQN 1A 15NJ04
L8	6200002330	S.COIL	LQN 1A 15NJ04
L9	6200004440	S.COIL	ELJFC 4R7M-F
L10	6200002330	S.COIL	LQN 1A 15NJ04
L11	6200002330	S.COIL	LQN 1A 15NJ04
L12	6200005730	S.COIL	ELJRE 39NG-F
L13	6200003290	S.COIL	ELJNC R12K-F
L14	6200002150	S.COIL	ELJNC 56NK-F
L15	6200002520	S.COIL	ELJNC R18K-F
L16	6110001590	COIL	LA-242
	6110001520	COIL	LA-232 [L/ML-band], [L] [MH-band]
L17	6200005690	S.COIL	ELJRE 18NG-F [P] [MH-band], [H-band]
L18	6200005700	S.COIL	ELJRE 22NG-F
L19	6200005680	S.COIL	ELJRE 15NG-F
L20	6200005690	S.COIL	ELJRE 18NG-F
L21	6200005690	S.COIL	ELJRE 18NG-F [H-band]
	6200005700	S.COIL	ELJRE 22NG-F other
L22	6200004230	S.COIL	ELJNC R56K-F
L23	6200003690	S.COIL	MC152-E558ANA-100051=P3
L24	6200001620	S.COIL	ELJFC 1R0K-F
L25	6200002520	S.COIL	ELJNC R18K-F
L26	6200003690	S.COIL	MC152-E558ANA-100051=P3 [L/ML-band]
	6200004110	S.COIL	MC152-E558ANA-100050 [MH/H-band]
L27	6200001620	S.COIL	ELJFC 1R0K-F
L28	6200005710	S.COIL	ELJRE 27NG-F
L30	6200005710	S.COIL	ELJRE 27NG-F
L31	6200005690	S.COIL	ELJRE 18NG-F
L32	6200004230	S.COIL	ELJNC R56K-F
L33	6200004230	S.COIL	ELJNC R56K-F
L34	6200005690	S.COIL	ELJRE 18NG-F
R1	7030000620	S.RESISTOR	MCR10EZJH 100 kΩ
R2	7030003320	S.RESISTOR	ERJ3GEYJ 101 V (100 Ω)
R3	7030003320	S.RESISTOR	ERJ3GEYJ 101 V (100 Ω)
R4	7030000220	S.RESISTOR	MCR10EZJH 47 Ω (470)
R5	7030003320	S.RESISTOR	ERJ3GEYJ 101 V (100 Ω)
R6	7030003320	S.RESISTOR	ERJ3GEYJ 101 V (100 Ω)
R7	7030000220	S.RESISTOR	MCR10EZJH 47 Ω (470)
R8	7030001170	S.RESISTOR	MCR50JZHJ 220 Ω (221)
R9	7030001170	S.RESISTOR	MCR50JZHJ 220 Ω (221)

[P]: PMR, [L]: LMR

S.=Surface mount

[MAIN UNIT]

REF NO.	ORDER NO.	DESCRIPTION
R10	7030003520	S.RESISTOR ERJ3GEYJ 472 V (4.7 kΩ)
R11	7030003720	S.RESISTOR ERJ3GEYJ 224 V (220 kΩ)
R12	7030003560	S.RESISTOR ERJ3GEYJ 103 V (10 kΩ)
R13	7030003720	S.RESISTOR ERJ3GEYJ 224 V (220 kΩ)
R14	7030003560	S.RESISTOR ERJ3GEYJ 103 V (10 kΩ)
R15	7030003640	S.RESISTOR ERJ3GEYJ 473 V (47 kΩ)
R16	7030003640	S.RESISTOR ERJ3GEYJ 473 V (47 kΩ)
R17	7030003680	S.RESISTOR ERJ3GEYJ 104 V (100 kΩ)
R18	7030003300	S.RESISTOR ERJ3GEYJ 680 V (68 Ω)
R19	7030003200	S.RESISTOR ERJ3GEYJ 100 V (10 Ω)
R20	7030003480	S.RESISTOR ERJ3GEYJ 222 V (2.2 kΩ)
R21	7030003720	S.RESISTOR ERJ3GEYJ 224 V (220 kΩ)
R22	7030003560	S.RESISTOR ERJ3GEYJ 103 V (10 kΩ)
R23	7030003720	S.RESISTOR ERJ3GEYJ 224 V (220 kΩ)
R24	7030003560	S.RESISTOR ERJ3GEYJ 103 V (10 kΩ)
R25	7030003680	S.RESISTOR ERJ3GEYJ 104 V (100 kΩ)
R27	7030003370	S.RESISTOR ERJ3GEYJ 271 V (270 Ω)
R28	7030003230	S.RESISTOR ERJ3GEYJ 180 V (18 Ω)
R29	7030003370	S.RESISTOR ERJ3GEYJ 271 V (270 Ω)
R30	7030003300	S.RESISTOR ERJ3GEYJ 680 V (68 Ω)
R31	7030003240	S.RESISTOR ERJ3GEYJ 220 V (22 Ω)
R32	7030003320	S.RESISTOR ERJ3GEYJ 101 V (100 Ω)
R33	7030003380	S.RESISTOR ERJ3GEYJ 331 V (330 Ω)
R34	7030003380	S.RESISTOR ERJ3GEYJ 331 V (330 Ω)
R35	7030003690	S.RESISTOR ERJ3GEYJ 124 V (120 kΩ)
R36	7030003320	S.RESISTOR ERJ3GEYJ 101 V (100 Ω)
R37	7030003450	S.RESISTOR ERJ3GEYJ 122 V (1.2 kΩ)
R38	7030003640	S.RESISTOR ERJ3GEYJ 473 V (47 kΩ)
R39	7030003640	S.RESISTOR ERJ3GEYJ 473 V (47 kΩ)
R40	7030003480	S.RESISTOR ERJ3GEYJ 222 V (2.2 kΩ)
R41	7030003400	S.RESISTOR ERJ3GEYJ 471 V (470 Ω)
R42	7030003680	S.RESISTOR ERJ3GEYJ 104 V (100 kΩ)
R44	7030003430	S.RESISTOR ERJ3GEYJ 821 V (820 Ω)
R45	7030003740	S.RESISTOR ERJ3GEYJ 334 V (330 kΩ)
R46	7030003680	S.RESISTOR ERJ3GEYJ 104 V (100 kΩ)
R47	7030003280	S.RESISTOR ERJ3GEYJ 470 V (47 Ω)
R48	7030003460	S.RESISTOR ERJ3GEYJ 152 V (1.5 kΩ)
R49	7030003580	S.RESISTOR ERJ3GEYJ 153 V (15 kΩ)
R50	7030003600	S.RESISTOR ERJ3GEYJ 223 V (22 kΩ)
R51	7030003570	S.RESISTOR ERJ3GEYJ 123 V (12 kΩ)
R52	7030003600	S.RESISTOR ERJ3GEYJ 223 V (22 kΩ)
R53	7030003580	S.RESISTOR ERJ3GEYJ 153 V (15 kΩ)
R54	7030000460	S.RESISTOR MCR10EZJH 4.7 kΩ
R55	7030000460	S.RESISTOR MCR10EZJH 4.7 kΩ
R56	7030000460	S.RESISTOR MCR10EZJH 4.7 kΩ
R57	7030000460	S.RESISTOR MCR10EZJH 4.7 kΩ
R58	7030003520	S.RESISTOR ERJ3GEYJ 472 V (4.7 kΩ)
R59	7030003560	S.RESISTOR ERJ3GEYJ 103 V (10 kΩ)
R60	7030003400	S.RESISTOR ERJ3GEYJ 471 V (470 Ω)
R61	7030003600	S.RESISTOR ERJ3GEYJ 223 V (22 kΩ)
		[H-band] other
R62	7030003590	S.RESISTOR ERJ3GEYJ 183 V (18 kΩ)
R63	7030003800	S.RESISTOR ERJ3GEYJ 105 V (1 MΩ)
R64	7030003700	S.RESISTOR ERJ3GEYJ 154 V (150 kΩ)
R65	7030003660	S.RESISTOR ERJ3GEYJ 683 V (68 kΩ)
R66	7030003660	S.RESISTOR ERJ3GEYJ 683 V (68 kΩ)
R67	7030003520	S.RESISTOR ERJ3GEYJ 472 V (4.7 kΩ)
R68	7030003450	S.RESISTOR ERJ3GEYJ 122 V (1.2 kΩ)
R69	7030003340	S.RESISTOR ERJ3GEYJ 151 V (150 Ω)
R70	7030000060	S.RESISTOR MCR10EZJH 2.2 Ω (2R2)
R71	7030000220	S.RESISTOR MCR10EZJH 47 Ω (470)
		[P] [L-band]
	7030000210	S.RESISTOR MCR10EZJH 39 Ω (390)
		[P] [ML/MH-band]
	7030000180	S.RESISTOR MCR10EZJH 22 Ω (220)
		[L] [H-band] other
R72	7030000200	S.RESISTOR MCR10EZJH 33 Ω (330)
	7030000220	S.RESISTOR MCR10EZJH 47 Ω (470)
		[P] [L/ML-band]
	7030000210	S.RESISTOR MCR10EZJH 39 Ω (390)
		[P] [MH/H-band]
	7030000200	S.RESISTOR MCR10EZJH 33 Ω (330)
		[L] [L/ML/MH-band]
	7030000190	S.RESISTOR MCR10EZJH 27 Ω (270)
		[L] [H-band]
R73	7030003480	S.RESISTOR ERJ3GEYJ 222 V (2.2 kΩ)
R74	7030003360	S.RESISTOR ERJ3GEYJ 221 V (220 Ω)
R75	7030003320	S.RESISTOR ERJ3GEYJ 101 V (100 Ω)
R76	7030003240	S.RESISTOR ERJ3GEYJ 220 V (22 Ω)
R77	7030003500	S.RESISTOR ERJ3GEYJ 332 V (3.3 kΩ)
R78	7030003460	S.RESISTOR ERJ3GEYJ 152 V (1.5 kΩ)

[MAIN UNIT]

REF NO.	ORDER NO.	DESCRIPTION
R79	7030003240	S.RESISTOR ERJ3GEYJ 220 V (22 Ω)
R80	7030003360	S.RESISTOR ERJ3GEYJ 221 V (220 Ω)
R81	7030003520	S.RESISTOR ERJ3GEYJ 472 V (4.7 kΩ)
R82	7030003490	S.RESISTOR ERJ3GEYJ 272 V (2.7 kΩ)
R83	7030003520	S.RESISTOR ERJ3GEYJ 472 V (4.7 kΩ)
R84	7030003440	S.RESISTOR ERJ3GEYJ 102 V (10 kΩ)
R85	7030003560	S.RESISTOR ERJ3GEYJ 103 V (10 kΩ)
R86	7030003440	S.RESISTOR ERJ3GEYJ 102 V (10 kΩ)
R87	7030003560	S.RESISTOR ERJ3GEYJ 103 V (10 kΩ)
R94	7030003460	S.RESISTOR ERJ3GEYJ 152 V (1.5 kΩ)
R95	7030003640	S.RESISTOR ERJ3GEYJ 473 V (47 kΩ)
R96	7030004850	S.RESISTOR ERJ3GEYF 913 V (91 kΩ)
R97	7030003640	S.RESISTOR ERJ3GEYJ 473 V (47 kΩ)
R98	7030003640	S.RESISTOR ERJ3GEYJ 473 V (47 kΩ)
R99	7030003480	S.RESISTOR ERJ3GEYJ 222 V (2.2 kΩ)
R100	7030005490	S.RESISTOR RR0816R-363-D (36 kΩ)
R101	7030004270	S.RESISTOR ERJ3EKF 4121 V (4.12 kΩ)
R102	7030004050	S.RESISTOR ERJ3GEYJ 1R0 V (1 Ω)
R103	7030003720	S.RESISTOR ERJ3GEYJ 224 V (220 kΩ)
R104	7030003600	S.RESISTOR ERJ3GEYJ 223 V (22 kΩ)
R105	7030003600	S.RESISTOR ERJ3GEYJ 223 V (22 kΩ)
R106	7030003730	S.RESISTOR ERJ3GEYJ 274 V (270 kΩ)
R107	7030003320	S.RESISTOR ERJ3GEYJ 101 V (100 Ω)
R108	7030003580	S.RESISTOR ERJ3GEYJ 153 V (15 kΩ)
R109	7030003560	S.RESISTOR ERJ3GEYJ 103 V (10 kΩ)
R110	7510000910	S.THERMISTOR NTCCF2012 4AH 473KC-T
R111	7030005870	S.RESISTOR RR0816R-104-D (100 kΩ)
R112	7030005650	S.RESISTOR RR0816R-304-D (300 kΩ)
R113	7030005870	S.RESISTOR RR0816R-104-D (100 kΩ)
R114	7030003200	S.RESISTOR ERJ3GEYJ 100 V (10 Ω)
R115	7030003540	S.RESISTOR ERJ3GEYJ 682 V (6.8 kΩ)
R116	7030003540	S.RESISTOR ERJ3GEYJ 682 V (6.8 kΩ)
R117	7030004050	S.RESISTOR ERJ3GEYJ 1R0 V (1 Ω)
R118	7030003440	S.RESISTOR ERJ3GEYJ 102 V (10 kΩ)
R119	7030003490	S.RESISTOR ERJ3GEYJ 272 V (2.7 kΩ)
		[ML-band] other
	7030003500	S.RESISTOR ERJ3GEYJ 332 V (3.3 kΩ)
R120	7030003680	S.RESISTOR ERJ3GEYJ 104 V (100 kΩ)
R121	7030003280	S.RESISTOR ERJ3GEYJ 470 V (47 Ω)
R122	7030003560	S.RESISTOR ERJ3GEYJ 103 V (10 kΩ)
R123	7030003520	S.RESISTOR ERJ3GEYJ 472 V (4.7 kΩ)
R124	7030003520	S.RESISTOR ERJ3GEYJ 472 V (4.7 kΩ)
R125	7030003200	S.RESISTOR ERJ3GEYJ 100 V (10 Ω)
R126	7030003410	S.RESISTOR ERJ3GEYJ 561 V (560 Ω)
R127	7030003520	S.RESISTOR ERJ3GEYJ 472 V (4.7 kΩ)
R128	7030003200	S.RESISTOR ERJ3GEYJ 100 V (10 Ω)
R129	7030003200	S.RESISTOR ERJ3GEYJ 100 V (10 Ω)
R130	7030003700	S.RESISTOR ERJ3GEYJ 154 V (150 kΩ)
R131	7030003360	S.RESISTOR ERJ3GEYJ 221 V (220 Ω)
R132	7030003710	S.RESISTOR ERJ3GEYJ 184 V (180 kΩ)
R133	7030003200	S.RESISTOR ERJ3GEYJ 100 V (10 Ω)
R134	7030003520	S.RESISTOR ERJ3GEYJ 472 V (4.7 kΩ)
R135	7030003520	S.RESISTOR ERJ3GEYJ 472 V (4.7 kΩ)
R136	7030003360	S.RESISTOR ERJ3GEYJ 221 V (220 Ω)
R137	7030003520	S.RESISTOR ERJ3GEYJ 472 V (4.7 kΩ)
R138	7030003370	S.RESISTOR ERJ3GEYJ 271 V (270 Ω)
R139	7030003230	S.RESISTOR ERJ3GEYJ 180 V (18 Ω)
R140	7030003370	S.RESISTOR ERJ3GEYJ 271 V (270 Ω)
R141	7030003560	S.RESISTOR ERJ3GEYJ 103 V (10 kΩ)
R142	7030003560	S.RESISTOR ERJ3GEYJ 103 V (10 kΩ)
R143	7030003440	S.RESISTOR ERJ3GEYJ 102 V (10 kΩ)
R144	7030003600	S.RESISTOR ERJ3GEYJ 223 V (22 kΩ)
R145	7030005640	S.RESISTOR RR0816R-753-D (75 kΩ)
R146	7030003670	S.RESISTOR ERJ3GEYJ 823 V (82 kΩ)
R147	7030003560	S.RESISTOR ERJ3GEYJ 103 V (10 kΩ)
R148	7030003680	S.RESISTOR ERJ3GEYJ 104 V (100 kΩ)
R150	7030003320	S.RESISTOR ERJ3GEYJ 101 V (100 Ω)
R151	7030003820	S.RESISTOR ERJ3GEYJ 155 V (1.5 MΩ)
R152	7030003530	S.RESISTOR ERJ3GEYJ 562 V (5.6 kΩ)
R153	7030003680	S.RESISTOR ERJ3GEYJ 104 V (100 kΩ)
R154	7030003320	S.RESISTOR ERJ3GEYJ 101 V (100 Ω)
R155	7030003560	S.RESISTOR ERJ3GEYJ 103 V (10 kΩ)
R156	7030003650	S.RESISTOR ERJ3GEYJ 563 V (56 kΩ)
R157	7030003730	S.RESISTOR ERJ3GEYJ 274 V (270 kΩ)
R158	7030003580	S.RESISTOR ERJ3GEYJ 153 V (15 kΩ)
R159	7030003620	S.RESISTOR ERJ3GEYJ 333 V (33 kΩ)
R160	7030003640	S.RESISTOR ERJ3GEYJ 473 V (47 kΩ)
R161	7030003760	S.RESISTOR ERJ3GEYJ 474 V (470 kΩ)
R162	7030003760	S.RESISTOR ERJ3GEYJ 474 V (470 kΩ)
R163	7030003560	S.RESISTOR ERJ3GEYJ 103 V (10 kΩ)
R164	7030003640	S.RESISTOR ERJ3GEYJ 473 V (47 kΩ)
R165	7030003560	S.RESISTOR ERJ3GEYJ 103 V (10 kΩ)

[P]: PMR, [L]: LMR

S.=Surface mount

[MAIN UNIT]

REF NO.	ORDER NO.	DESCRIPTION	
R166	7030003560	S.RESISTOR	ERJ3GEYJ 103 V (10 kΩ)
R167	7030003320	S.RESISTOR	ERJ3GEYJ 101 V (100 Ω)
R168	7030003680	S.RESISTOR	ERJ3GEYJ 104 V (100 kΩ)
R169	7030003440	S.RESISTOR	ERJ3GEYJ 102 V (1 kΩ)
R170	7030003540	S.RESISTOR	ERJ3GEYJ 682 V (6.8 kΩ)
R172	7030003560	S.RESISTOR	ERJ3GEYJ 103 V (10 kΩ)
R173	7030003560	S.RESISTOR	ERJ3GEYJ 103 V (10 kΩ)
R174	7030003400	S.RESISTOR	ERJ3GEYJ 471 V (470 Ω)
R175	7030003560	S.RESISTOR	ERJ3GEYJ 103 V (10 kΩ)
R176	7030003800	S.RESISTOR	ERJ3GEYJ 105 V (1 MΩ)
R177	7030003660	S.RESISTOR	ERJ3GEYJ 683 V (68 kΩ)
R178	7030003680	S.RESISTOR	ERJ3GEYJ 104 V (100 kΩ)
R179	7030003440	S.RESISTOR	ERJ3GEYJ 102 V (1 kΩ)
R180	7030003560	S.RESISTOR	ERJ3GEYJ 103 V (10 kΩ)
R181	7030003440	S.RESISTOR	ERJ3GEYJ 102 V (1 kΩ)
R182	7030003200	S.RESISTOR	ERJ3GEYJ 100 V (10 Ω)
R184	7030003490	S.RESISTOR	ERJ3GEYJ 272 V (2.7 kΩ)
R185	7030003320	S.RESISTOR	ERJ3GEYJ 101 V (100 Ω)
R186	7030003680	S.RESISTOR	ERJ3GEYJ 104 V (100 kΩ)
R187	7030003440	S.RESISTOR	ERJ3GEYJ 102 V (1 kΩ)
R188	7030003440	S.RESISTOR	ERJ3GEYJ 102 V (1 kΩ)
R189	7030003440	S.RESISTOR	ERJ3GEYJ 102 V (1 kΩ)
R190	7030003440	S.RESISTOR	ERJ3GEYJ 102 V (1 kΩ)
R191	7030003290	S.RESISTOR	ERJ3GEYJ 560 V (56 Ω)
R193	7030003760	S.RESISTOR	ERJ3GEYJ 474 V (470 kΩ)
R194	7030003710	S.RESISTOR	ERJ3GEYJ 184 V (180 kΩ)
R195	7030003720	S.RESISTOR	ERJ3GEYJ 224 V (220 kΩ)
R198	7030003560	S.RESISTOR	ERJ3GEYJ 103 V (10 kΩ)
R199	7030003400	S.RESISTOR	ERJ3GEYJ 471 V (470 Ω)
R204	7030003560	S.RESISTOR	ERJ3GEYJ 103 V (10 kΩ)
R205	7030003560	S.RESISTOR	ERJ3GEYJ 103 V (10 kΩ)
R206	7030003680	S.RESISTOR	ERJ3GEYJ 104 V (100 kΩ)
R207	7030003440	S.RESISTOR	ERJ3GEYJ 102 V (1 kΩ)
R208	7030003560	S.RESISTOR	ERJ3GEYJ 103 V (10 kΩ)
R209	7030003680	S.RESISTOR	ERJ3GEYJ 104 V (100 kΩ)
R210	7030003800	S.RESISTOR	ERJ3GEYJ 105 V (1 MΩ)
R211	7030003680	S.RESISTOR	ERJ3GEYJ 104 V (100 kΩ)
R212	7030003800	S.RESISTOR	ERJ3GEYJ 105 V (1 MΩ)
R213	7030003680	S.RESISTOR	ERJ3GEYJ 104 V (100 kΩ)
R214	7030003680	S.RESISTOR	ERJ3GEYJ 104 V (100 kΩ)
R215	7030003680	S.RESISTOR	ERJ3GEYJ 104 V (100 kΩ)
R216	7030003800	S.RESISTOR	ERJ3GEYJ 105 V (1 MΩ)
R217	7030003800	S.RESISTOR	ERJ3GEYJ 105 V (1 MΩ)
R218	7030003800	S.RESISTOR	ERJ3GEYJ 105 V (1 MΩ)
R219	7030003440	S.RESISTOR	ERJ3GEYJ 102 V (1 kΩ)
R220	7030003440	S.RESISTOR	ERJ3GEYJ 102 V (1 kΩ)
R221	7030003440	S.RESISTOR	ERJ3GEYJ 102 V (1 kΩ)
R222	7030003440	S.RESISTOR	ERJ3GEYJ 102 V (1 kΩ)
R223	7030003440	S.RESISTOR	ERJ3GEYJ 102 V (1 kΩ)
R224	7030003440	S.RESISTOR	ERJ3GEYJ 102 V (1 kΩ)
R225	7030003440	S.RESISTOR	ERJ3GEYJ 102 V (1 kΩ)
R226	7030003440	S.RESISTOR	ERJ3GEYJ 102 V (1 kΩ)
R227	7030003440	S.RESISTOR	ERJ3GEYJ 102 V (1 kΩ)
R228	7030003440	S.RESISTOR	ERJ3GEYJ 102 V (1 kΩ)
R229	7030003440	S.RESISTOR	ERJ3GEYJ 102 V (1 kΩ)
R230	7030003440	S.RESISTOR	ERJ3GEYJ 102 V (1 kΩ)
R231	7030003440	S.RESISTOR	ERJ3GEYJ 102 V (1 kΩ)
R232	7030003440	S.RESISTOR	ERJ3GEYJ 102 V (1 kΩ)
R233	7030003440	S.RESISTOR	ERJ3GEYJ 102 V (1 kΩ)
R234	7030003440	S.RESISTOR	ERJ3GEYJ 102 V (1 kΩ)
R235	7030003440	S.RESISTOR	ERJ3GEYJ 102 V (1 kΩ)
R236	7030003440	S.RESISTOR	ERJ3GEYJ 102 V (1 kΩ)
R237	7030003440	S.RESISTOR	ERJ3GEYJ 102 V (1 kΩ)
R238	7030003440	S.RESISTOR	ERJ3GEYJ 102 V (1 kΩ)
R239	7030003440	S.RESISTOR	ERJ3GEYJ 102 V (1 kΩ)
R240	7030003440	S.RESISTOR	ERJ3GEYJ 102 V (1 kΩ)
R241	7030003440	S.RESISTOR	ERJ3GEYJ 102 V (1 kΩ)
R242	7030003440	S.RESISTOR	ERJ3GEYJ 102 V (1 kΩ)
R243	7030003440	S.RESISTOR	ERJ3GEYJ 102 V (1 kΩ)
R245	7030003440	S.RESISTOR	ERJ3GEYJ 102 V (1 kΩ)
R246	7030003440	S.RESISTOR	ERJ3GEYJ 102 V (1 kΩ)
R247	7030003440	S.RESISTOR	ERJ3GEYJ 102 V (1 kΩ)
R248	7030003440	S.RESISTOR	ERJ3GEYJ 102 V (1 kΩ)
R249	7030003440	S.RESISTOR	ERJ3GEYJ 102 V (1 kΩ)
R250	7030003440	S.RESISTOR	ERJ3GEYJ 102 V (1 kΩ)
R251	7030003440	S.RESISTOR	ERJ3GEYJ 102 V (1 kΩ)
R252	7030003440	S.RESISTOR	ERJ3GEYJ 102 V (1 kΩ)
R254	7030003760	S.RESISTOR	ERJ3GEYJ 474 V (470 kΩ)
R255	7030003560	S.RESISTOR	ERJ3GEYJ 103 V (10 kΩ)
R257	7030003280	S.RESISTOR	ERJ3GEYJ 470 V (47 Ω)
R258	7030003640	S.RESISTOR	ERJ3GEYJ 473 V (47 kΩ)
R259	7030003600	S.RESISTOR	ERJ3GEYJ 223 V (22 kΩ)

[MAIN UNIT]

REF NO.	ORDER NO.	DESCRIPTION	
R260	7030003550	S.RESISTOR	ERJ3GEYJ 822 V (8.2 kΩ)
			[MH-band] other
	7030003570	S.RESISTOR	ERJ3GEYJ 123 V (12 kΩ)
R264	7030003560	S.RESISTOR	ERJ3GEYJ 103 V (10 kΩ)
R265	7030003550	S.RESISTOR	ERJ3GEYJ 822 V (8.2 kΩ)
R266	7030003560	S.RESISTOR	ERJ3GEYJ 103 V (10 kΩ)
R267	7030003730	S.RESISTOR	ERJ3GEYJ 274 V (270 kΩ)
R268	7030003560	S.RESISTOR	ERJ3GEYJ 103 V (10 kΩ)
R269	7030003630	S.RESISTOR	ERJ3GEYJ 393 V (39 kΩ)
R270	7030003800	S.RESISTOR	ERJ3GEYJ 105 V (1 MΩ)
R271	7030003560	S.RESISTOR	ERJ3GEYJ 103 V (10 kΩ)
R272	7030003440	S.RESISTOR	ERJ3GEYJ 102 V (1 kΩ)
R273	7030003790	S.RESISTOR	ERJ3GEYJ 824 V (820 kΩ)
R274	7030003440	S.RESISTOR	ERJ3GEYJ 102 V (1 kΩ)
R275	7030003440	S.RESISTOR	ERJ3GEYJ 102 V (1 kΩ)
R276	7030003200	S.RESISTOR	ERJ3GEYJ 100 V (10 Ω)
R277	7030003400	S.RESISTOR	ERJ3GEYJ 471 V (470 Ω)
R278	7030003560	S.RESISTOR	ERJ3GEYJ 103 V (10 kΩ)
R280	7030003680	S.RESISTOR	ERJ3GEYJ 104 V (100 kΩ)
R281	7030003580	S.RESISTOR	ERJ3GEYJ 153 V (15 kΩ)
R282	7030004050	S.RESISTOR	ERJ3GEYJ 1R0 V (1 Ω)
C1	4030011090	S.CERAMIC	GRM42-6 CH 070D 500PT [L/ML-band]
	4030011070	S.CERAMIC	GRM42-6 CH 050C 500PT [P] [MH-band]
	4030011080	S.CERAMIC	GRM42-6 CH 060D 500PT [L] [MH-band], [H-band]
C2	4030011090	S.CERAMIC	GRM42-6 CH 070D 500PT [L/ML-band]
	4030011070	S.CERAMIC	GRM42-6 CH 050C 500PT [P] [MH-band]
	4030011080	S.CERAMIC	GRM42-6 CH 060D 500PT [L] [MH-band], [H-band]
C3	4030006860	S.CERAMIC	C1608 JB 1H 102K-T-A
C5	4030006860	S.CERAMIC	C1608 JB 1H 102K-T-A
C6	4030006860	S.CERAMIC	C1608 JB 1H 102K-T-A
C7	4030006980	S.CERAMIC	C1608 CH 1H 070D-T-A
C8	4030006860	S.CERAMIC	C1608 JB 1H 102K-T-A
C9	4030011090	S.CERAMIC	GRM42-6 CH 070D 500PT [L/ML-band]
	4030011070	S.CERAMIC	GRM42-6 CH 050C 500PT [P] [MH-band]
	4030011060	S.CERAMIC	GRM42-6 CH 040C 500PT [H-band]
	4030011080	S.CERAMIC	GRM42-6 CH 060D 500PT [L] [MH-band]
C10	4030011110	S.CERAMIC	GRM42-6 CH 090D 500PT [L/ML-band]
	4030011080	S.CERAMIC	GRM42-6 CH 060D 500PT [P] [MH-band]
	4030011100	S.CERAMIC	GRM42-6 CH 080D 500PT [L] [MH-band], [H-band]
C11	4030011040	S.CERAMIC	GRM42-6 CK 020C 500PT [L-band]
	4030011020	S.CERAMIC	GRM42-6 CK 010C 500PT other
C12	4030011070	S.CERAMIC	GRM42-6 CH 050C 500PT [L/ML-band], [L] [H-band]
	4030011060	S.CERAMIC	GRM42-6 CH 040C 500PT [P] [MH/H-band]
	4030011050	S.CERAMIC	GRM42-6 CJ 030C 500PT [L] [MH-band]
C13	4030011240	S.CERAMIC	GRM42-6 CH 470J 500PT [P]
	4010005730	CERAMIC	HM60SJ SL 470J 500V [L]
C14	4030011070	S.CERAMIC	GRM42-6 CH 050C 500PT [P] [L/ML/MH-band]
	4030011050	S.CERAMIC	GRM42-6 CJ 030C 500PT [L] [MH-band], [H-band]
	4030011060	S.CERAMIC	GRM42-6 CH 040C 500PT [L] [L/ML-band]
C15	4030007090	S.CERAMIC	C1608 CH 1H 470J-T-A
C16	4030006850	S.CERAMIC	C1608 JB 1H 471K-T-A
C17	4030011040	S.CERAMIC	GRM42-6 CK 020C 500PT [H-band]
	4030011100	S.CERAMIC	GRM42-6 CH 080D 500PT other
C18	4030009550	S.CERAMIC	C1608 CH 1H 2R5B-T-A
C19	4030006860	S.CERAMIC	C1608 JB 1H 102K-T-A
C20	4030009540	S.CERAMIC	C1608 CH 1H 1R5B-T-A
C21	4030007090	S.CERAMIC	C1608 CH 1H 470J-T-A

[P]: PMR, [L]: LMR

S.=Surface mount

[MAIN UNIT]

REF NO.	ORDER NO.	DESCRIPTION	
C22	4030011770	S.CERAMIC	C1608 CH 1H 060B-T-A [L-band]
	4030009920	S.CERAMIC	C1608 CH 1H 050B-T-A [ML/H-band]
	4030009910	S.CERAMIC	C1608 CH 1H 040B-T-A [MH-band]
	4030009520	S.CERAMIC	C1608 CH 1H 020B-T-A [L-band]
C23	4030009540	S.CERAMIC	C1608 CH 1H 1R5B-T-A [ML/MH-band]
	4030009510	S.CERAMIC	C1608 CH 1H 010B-T-A [L-band]
C24	4030009500	S.CERAMIC	C1608 CH 1H 0R5B-T-A other
	4030009560	S.CERAMIC	C1608 CH 1H R75B-T-A [H-band]
C25	4030009510	S.CERAMIC	C1608 CH 1H 010B-T-A other
	4030006980	S.CERAMIC	C1608 CH 1H 070D-T-A [L-band]
C26	4030011770	S.CERAMIC	C1608 CH 1H 060B-T-A [ML-band]
	4030009920	S.CERAMIC	C1608 CH 1H 050B-T-A [MH/H-band]
C27	4030007090	S.CERAMIC	C1608 CH 1H 470J-T-A
C28	4030009540	S.CERAMIC	C1608 CH 1H 1R5B-T-A [L-band]
	4030009500	S.CERAMIC	C1608 CH 1H 0R5B-T-A [ML/MH-band]
C29	4030009550	S.CERAMIC	C1608 CH 1H 2R5B-T-A [H-band]
	4030009910	S.CERAMIC	C1608 CH 1H 040B-T-A other
C30	4030006860	S.CERAMIC	C1608 JB 1H 102K-T-A
C31	4030006860	S.CERAMIC	C1608 JB 1H 102K-T-A
C32	4030009550	S.CERAMIC	C1608 CH 1H 2R5B-T-A [L-band]
	4030009540	S.CERAMIC	C1608 CH 1H 1R5B-T-A [ML-band]
	4030009520	S.CERAMIC	C1608 CH 1H 020B-T-A [MH-band]
	4030009510	S.CERAMIC	C1608 CH 1H 010B-T-A [H-band]
C33	4030007090	S.CERAMIC	C1608 CH 1H 470J-T-A
C34	4030006980	S.CERAMIC	C1608 CH 1H 070D-T-A [L-band]
	4030011770	S.CERAMIC	C1608 CH 1H 060B-T-A [ML-band]
	4030009910	S.CERAMIC	C1608 CH 1H 040B-T-A [MH/H-band]
	4030007090	S.CERAMIC	C1608 CH 1H 470J-T-A
C36	4030009500	S.CERAMIC	C1608 CH 1H 0R5B-T-A
C37	4030009510	S.CERAMIC	C1608 CH 1H 010B-T-A [L-band]
	4030009570	S.CERAMIC	C1608 CH 1H 0R3B-T-A other
C38	4030009550	S.CERAMIC	C1608 CH 1H 2R5B-T-A [L-band]
	4030009540	S.CERAMIC	C1608 CH 1H 1R5B-T-A [ML/MH-band]
C39	4030009500	S.CERAMIC	C1608 CH 1H 0R5B-T-A [H-band]
	4030006980	S.CERAMIC	C1608 CH 1H 070D-T-A [L-band]
	4030011770	S.CERAMIC	C1608 CH 1H 060B-T-A [ML-band]
	4030009920	S.CERAMIC	C1608 CH 1H 050B-T-A [MH/H-band]
C40	4030007090	S.CERAMIC	C1608 CH 1H 470J-T-A
C41	4030009510	S.CERAMIC	C1608 CH 1H 010B-T-A
C42	4030009530	S.CERAMIC	C1608 CH 1H 030B-T-A
C43	4030006860	S.CERAMIC	C1608 JB 1H 102K-T-A
C44	4030006860	S.CERAMIC	C1608 JB 1H 102K-T-A
C45	4030007110	S.CERAMIC	C1608 CH 1H 680J-T-A
C46	4030006860	S.CERAMIC	C1608 JB 1H 102K-T-A
C47	4030007020	S.CERAMIC	C1608 CH 1H 120J-T-A
C48	4030006860	S.CERAMIC	C1608 JB 1H 102K-T-A
C49	4030006860	S.CERAMIC	C1608 JB 1H 102K-T-A
C50	4030007110	S.CERAMIC	C1608 CH 1H 680J-T-A
C51	4030007130	S.CERAMIC	C1608 CH 1H 101J-T-A
C52	4030007130	S.CERAMIC	C1608 CH 1H 101J-T-A
C54	4030006860	S.CERAMIC	C1608 JB 1H 102K-T-A
C55	4030006860	S.CERAMIC	C1608 JB 1H 102K-T-A
C56	4030006860	S.CERAMIC	C1608 JB 1H 102K-T-A
C57	4550006320	S.TANTALUM	ECST0JY475R
C58	4030006860	S.CERAMIC	C1608 JB 1H 102K-T-A
C59	4030006860	S.CERAMIC	C1608 JB 1H 102K-T-A
C60	4030006900	S.CERAMIC	C1608 JB 1E 103K-T-A
C61	4030011280	S.CERAMIC	C1608 CH 1H 271J-T-A
C62	4030011280	S.CERAMIC	C1608 CH 1H 271J-T-A
C63	4030011600	S.CERAMIC	C1608 JB 1C 104KT-N
C64	4030011600	S.CERAMIC	C1608 JB 1C 104KT-N
C65	4030006900	S.CERAMIC	C1608 JB 1E 103K-T-A
C66	4030006900	S.CERAMIC	C1608 JB 1E 103K-T-A
C67	4030007090	S.CERAMIC	C1608 CH 1H 470J-T-A
C68	4510004630	S.ELECTROLYTIC	ECEV1CA100SR
C69	4550006540	S.TANTALUM	ECST1CY475R
C70	4030007090	S.CERAMIC	C1608 CH 1H 470J-T-A
C71	4510004630	S.ELECTROLYTIC	ECEV1CA100SR
C72	4550006450	S.TANTALUM	ECST1EY105R

[P]: PMR, [L]: LMR

[MAIN UNIT]

REF NO.	ORDER NO.	DESCRIPTION	
C73	4030004760	S.CERAMIC	C2012 JF 1E 104Z-T-A
C74	4510005290	S.ELECTROLYTIC	ECEV1EA221P
C75	4510004630	S.ELECTROLYTIC	ECEV1CA100SR
C76	4030008630	S.CERAMIC	C1608 JF 1C 104Z-T-A
C77	4030006860	S.CERAMIC	C1608 JB 1H 102K-T-A
C78	4510004630	S.ELECTROLYTIC	ECEV1CA100SR
C79	4510004630	S.ELECTROLYTIC	ECEV1CA100SR
C80	4030008630	S.CERAMIC	C1608 JF 1C 104Z-T-A
C81	4030004760	S.CERAMIC	C2012 JF 1E 104Z-T-A
C82	4030006900	S.CERAMIC	C1608 JB 1E 103K-T-A
C83	4030004760	S.CERAMIC	C2012 JF 1E 104Z-T-A
C84	4510004510	ELECTROLYTIC	25 MV 470 HC
C85	4030006860	S.CERAMIC	C1608 JB 1H 102K-T-A
C86	4030007090	S.CERAMIC	C1608 CH 1H 470J-T-A
C87	4030007090	S.CERAMIC	C1608 CH 1H 470J-T-A
C88	4030008880	S.CERAMIC	C1608 JB 1C 223K-T-A
C89	4030006860	S.CERAMIC	C1608 JB 1H 102K-T-A
C90	4030008630	S.CERAMIC	C1608 JF 1C 104Z-T-A
C91	4510006850	S.ELECTROLYTIC	ECEV 1CA 4R7NR (16V 4.7)
C92	4510004630	S.ELECTROLYTIC	ECEV1CA100SR
C93	4030011050	S.CERAMIC	GRM42-6 CJ 030C 500PT [L/ML-band]
	4030011060	S.CERAMIC	GRM42-6 CH 040C 500PT [MH/H-band]
	4010005440	CERAMIC	HM60SJ CH 060D 500V [L-band]
	4010005420	CERAMIC	HM60SJ CH 040C 500V [ML/MH/H-band]
C94	4030011050	S.CERAMIC	GRM42-6 CJ 030C 500PT [L/ML-band]
	4030011070	S.CERAMIC	GRM42-6 CH 050C 500PT [MH-band]
	4030011040	S.CERAMIC	GRM42-6 CK 020C 500PT [H-band]
	4010005410	CERAMIC	HM60SJ CJ 030C 500V [L-band]
	4010005440	CERAMIC	HM60SJ CH 060D 500V [ML-band]
	4010005420	CERAMIC	HM60SJ CH 040C 500V [MH-band]
	4010005400	CERAMIC	HM60SJ CK 020C 500V [H-band]
	C95	4510005750	S.ELECTROLYTIC
C96	4030006860	S.CERAMIC	C1608 JB 1H 102K-T-A
C97	4030007090	S.CERAMIC	C1608 CH 1H 470J-T-A
C98	4030006860	S.CERAMIC	C1608 JB 1H 102K-T-A
C99	4030007090	S.CERAMIC	C1608 CH 1H 470J-T-A
C100	4510005750	S.ELECTROLYTIC	ECEV1EA220SP
C101	4030009910	S.CERAMIC	C1608 CH 1H 040B-T-A [H-band]
	4030009920	S.CERAMIC	C1608 CH 1H 050B-T-A other
C102	4030006980	S.CERAMIC	C1608 CH 1H 070D-T-A [H-band]
	4030006990	S.CERAMIC	C1608 CH 1H 080D-T-A other
C103	4030011770	S.CERAMIC	C1608 CH 1H 060B-T-A
C104	4030006850	S.CERAMIC	C1608 JB 1H 471K-T-A
C105	4030006850	S.CERAMIC	C1608 JB 1H 471K-T-A
C107	4030006850	S.CERAMIC	C1608 JB 1H 471K-T-A
C108	4030006990	S.CERAMIC	C1608 CH 1H 080D-T-A [H-band]
	4030007010	S.CERAMIC	C1608 CH 1H 100D-T-A other
C109	4030009920	S.CERAMIC	C1608 CH 1H 050B-T-A [H-band]
	4030011770	S.CERAMIC	C1608 CH 1H 060B-T-A other
C110	4030006860	S.CERAMIC	C1608 JB 1H 102K-T-A
C111	4030006860	S.CERAMIC	C1608 JB 1H 102K-T-A
C112	4030006860	S.CERAMIC	C1608 JB 1H 102K-T-A
C113	4030006980	S.CERAMIC	C1608 CH 1H 070D-T-A
C115	4030006860	S.CERAMIC	C1608 JB 1H 102K-T-A
C116	4030006860	S.CERAMIC	C1608 JB 1H 102K-T-A
C117	4030007090	S.CERAMIC	C1608 CH 1H 470J-T-A
C118	4030006850	S.CERAMIC	C1608 JB 1H 471K-T-A
C119	4030006860	S.CERAMIC	C1608 JB 1H 102K-T-A
C120	4030006850	S.CERAMIC	C1608 JB 1H 471K-T-A
C121	4030007010	S.CERAMIC	C1608 CH 1H 100D-T-A
C126	4030008920	S.CERAMIC	C1608 JB 1C 473K-T-A
C127	4030008920	S.CERAMIC	C1608 JB 1C 473K-T-A
C128	4030008920	S.CERAMIC	C1608 JB 1C 473K-T-A
C129	4030008920	S.CERAMIC	C1608 JB 1C 473K-T-A
C130	4030008920	S.CERAMIC	C1608 JB 1C 473K-T-A
C131	4030006850	S.CERAMIC	C1608 JB 1H 471K-T-A
C132	4030011310	S.CERAMIC	C2012 JB 1A 564K-T-A
C133	4030008630	S.CERAMIC	C1608 JF 1C 104Z-T-A
C134	4030006860	S.CERAMIC	C1608 JB 1H 102K-T-A
C135	4550006170	S.TANTALUM	ECST1AY225R

S.=Surface mount

[MAIN UNIT]

REF NO.	ORDER NO.	DESCRIPTION	
C137	4030006850	S.CERAMIC	C1608 JB 1H 471K-T-A
C138	4030006860	S.CERAMIC	C1608 JB 1H 102K-T-A
C139	4030008230	S.CERAMIC	C1608 UJ 1H 080D-T-A [L-band]
	4030008210	S.CERAMIC	C1608 UJ 1H 060D-T-A [ML-band]
	4030008190	S.CERAMIC	C1608 UJ 1H 040C-T-A [MH/H-band]
C141	4030008270	S.CERAMIC	C1608 UJ 1H 180J-T-A [L-band]
	4030008260	S.CERAMIC	C1608 UJ 1H 150J-T-A [ML/MH-band]
	4030008250	S.CERAMIC	C1608 UJ 1H 120J-T-A [H-band]
C142	4030007010	S.CERAMIC	C1608 CH 1H 100D-T-A [L-band]
	4030011770	S.CERAMIC	C1608 CH 1H 060B-T-A [ML-band]
	4030009920	S.CERAMIC	C1608 CH 1H 050B-T-A [MH-band]
	4030009530	S.CERAMIC	C1608 CH 1H 030B-T-A [H-band]
C143	4030007020	S.CERAMIC	C1608 CH 1H 120J-T-A [L-band]
	4030006990	S.CERAMIC	C1608 CH 1H 080D-T-A [ML-band]
	4030011770	S.CERAMIC	C1608 CH 1H 060B-T-A [MH-band]
	4030009920	S.CERAMIC	C1608 CH 1H 050B-T-A [H-band]
C144	4030006860	S.CERAMIC	C1608 JB 1H 102K-T-A
C145	4030007090	S.CERAMIC	C1608 CH 1H 470J-T-A
C146	4030009500	S.CERAMIC	C1608 CH 1H 0R5B-T-A
C147	4030009510	S.CERAMIC	C1608 CH 1H 010B-T-A
C148	4030008200	S.CERAMIC	C1608 UJ 1H 050C-T-A [L/MH-band]
	4030008190	S.CERAMIC	C1608 UJ 1H 040C-T-A [ML/H-band]
C149	4030009510	S.CERAMIC	C1608 CH 1H 010B-T-A [MH-band]
	4030009350	S.CERAMIC	C1608 CH 1H 3R5B-T-A [H-band]
C150	4030008240	S.CERAMIC	C1608 UJ 1H 100D-T-A [L-band]
	4030008230	S.CERAMIC	C1608 UJ 1H 080D-T-A [ML-band]
	4030008260	S.CERAMIC	C1608 UJ 1H 150J-T-A [MH-band]
	4030008190	S.CERAMIC	C1608 UJ 1H 040C-T-A [H-band]
C151	4030009920	S.CERAMIC	C1608 CH 1H 050B-T-A [L-band]
	4030009520	S.CERAMIC	C1608 CH 1H 020B-T-A [ML-band]
	4030006990	S.CERAMIC	C1608 CH 1H 080D-T-A [MH-band]
	4030009530	S.CERAMIC	C1608 CH 1H 030B-T-A [H-band]
C152	4030006990	S.CERAMIC	C1608 CH 1H 080D-T-A [L/MH-band]
	4030009910	S.CERAMIC	C1608 CH 1H 040B-T-A [ML-band]
	4030009530	S.CERAMIC	C1608 CH 1H 030B-T-A [H-band]
C153	4030006860	S.CERAMIC	C1608 JB 1H 102K-T-A
C154	4030007090	S.CERAMIC	C1608 CH 1H 470J-T-A
C155	4030009500	S.CERAMIC	C1608 CH 1H 0R5B-T-A
C156	4030006850	S.CERAMIC	C1608 JB 1H 471K-T-A
C157	4030006850	S.CERAMIC	C1608 JB 1H 471K-T-A
C158	4030007020	S.CERAMIC	C1608 CH 1H 120J-T-A
C159	4030009520	S.CERAMIC	C1608 CH 1H 020B-T-A
C160	4030006980	S.CERAMIC	C1608 CH 1H 070D-T-A
C161	4030006850	S.CERAMIC	C1608 JB 1H 471K-T-A
C162	4030011770	S.CERAMIC	C1608 CH 1H 060B-T-A
C163	4030006860	S.CERAMIC	C1608 JB 1H 102K-T-A
C164	4030011770	S.CERAMIC	C1608 CH 1H 060B-T-A
C165	4030011770	S.CERAMIC	C1608 CH 1H 060B-T-A
C166	4030006860	S.CERAMIC	C1608 JB 1H 102K-T-A
C167	4510004630	S.ELECTROLYTIC	ECEV1CA100SR
C169	4030007020	S.CERAMIC	C1608 CH 1H 120J-T-A
C170	4030009920	S.CERAMIC	C1608 CH 1H 050B-T-A
C171	4030009910	S.CERAMIC	C1608 CH 1H 040B-T-A
C172	4030009920	S.CERAMIC	C1608 CH 1H 050B-T-A
C173	4030007020	S.CERAMIC	C1608 CH 1H 120J-T-A
C174	4030011600	S.CERAMIC	C1608 JB 1C 104KT-N
C175	4030011600	S.CERAMIC	C1608 JB 1C 104KT-N
C176	4550006560	S.TANTALUM	ECST1CY225R
C177	4030006860	S.CERAMIC	C1608 JB 1H 102K-T-A
C178	4030007090	S.CERAMIC	C1608 CH 1H 470J-T-A
C179	4030008630	S.CERAMIC	C1608 JF 1C 104Z-T-A
C180	4030011600	S.CERAMIC	C1608 JB 1C 104KT-N
C183	4030008630	S.CERAMIC	C1608 JF 1C 104Z-T-A
C184	4030007030	S.CERAMIC	C1608 CH 1H 150J-T-A
C185	4030011600	S.CERAMIC	C1608 JB 1C 104KT-N
C186	4030011600	S.CERAMIC	C1608 JB 1C 104KT-N

[MAIN UNIT]

REF NO.	ORDER NO.	DESCRIPTION	
C187	4030011600	S.CERAMIC	C1608 JB 1C 104KT-N
C188	4550006320	S.TANTALUM	ECST0JY475R
C189	4030011600	S.CERAMIC	C1608 JB 1C 104KT-N
C190	4030008630	S.CERAMIC	C1608 JF 1C 104Z-T-A
C191	4030008850	S.CERAMIC	C1608 JB 1C 123K-T-A
C193	4030011600	S.CERAMIC	C1608 JB 1C 104KT-N
C194	4510005290	S.ELECTROLYTIC	ECEV1EA221P
C195	4510006260	S.ELECTROLYTIC	ECEV1AA471UP
C196	4030006860	S.CERAMIC	C1608 JB 1H 102K-T-A
C197	4030006860	S.CERAMIC	C1608 JB 1H 102K-T-A
C198	4510004630	S.ELECTROLYTIC	ECEV1CA100SR
C199	4030006860	S.CERAMIC	C1608 JB 1H 102K-T-A
C200	4030006860	S.CERAMIC	C1608 JB 1H 102K-T-A
C201	4550006360	S.TANTALUM	ECST1VY104R
C202	4030008880	S.CERAMIC	C1608 JB 1C 223K-T-A
C203	4550006430	S.TANTALUM	ECST1VY474R
C204	4550006430	S.TANTALUM	ECST1VY474R
C205	4030006860	S.CERAMIC	C1608 JB 1H 102K-T-A
C206	4510004630	S.ELECTROLYTIC	ECEV1CA100SR
C207	4030006850	S.CERAMIC	C1608 JB 1H 471K-T-A
C208	4030006880	S.CERAMIC	C1608 JB 1H 472K-T-A
C209	4030006860	S.CERAMIC	C1608 JB 1H 102K-T-A
C210	4550006170	S.TANTALUM	ECST1AY225R
C211	4030008630	S.CERAMIC	C1608 JF 1C 104Z-T-A
C212	4510006850	S.ELECTROLYTIC	ECEV 1CA 4R7NR (16V 4.7)
C213	4030006860	S.CERAMIC	C1608 JB 1H 102K-T-A
C214	4030006990	S.CERAMIC	C1608 CH 1H 080D-T-A
C215	4030006990	S.CERAMIC	C1608 CH 1H 080D-T-A
C216	4030007050	S.CERAMIC	C1608 CH 1H 220J-T-A
C217	4030007050	S.CERAMIC	C1608 CH 1H 220J-T-A
C218	4030007050	S.CERAMIC	C1608 CH 1H 220J-T-A
C219	4030006860	S.CERAMIC	C1608 JB 1H 102K-T-A
C221	4030008470	S.CERAMIC	C1608 JB 1H 272K-T-A
C222	4030007040	S.CERAMIC	C1608 CH 1H 180J-T-A
C223	4030007020	S.CERAMIC	C1608 CH 1H 120J-T-A
C225	4030006900	S.CERAMIC	C1608 JB 1E 103K-T-A
C226	4030006900	S.CERAMIC	C1608 JB 1E 103K-T-A
C227	4030006900	S.CERAMIC	C1608 JB 1E 103K-T-A
C228	4030006860	S.CERAMIC	C1608 JB 1H 102K-T-A
C229	4030006860	S.CERAMIC	C1608 JB 1H 102K-T-A
C230	4030006860	S.CERAMIC	C1608 JB 1H 102K-T-A
C231	4030006860	S.CERAMIC	C1608 JB 1H 102K-T-A
C232	4030006900	S.CERAMIC	C1608 JB 1E 103K-T-A
C233	4030006860	S.CERAMIC	C1608 JB 1H 102K-T-A
C234	4030006860	S.CERAMIC	C1608 JB 1H 102K-T-A
C235	4030006860	S.CERAMIC	C1608 JB 1H 102K-T-A
C236	4030011600	S.CERAMIC	C1608 JB 1C 104KT-N
C237	4030010210	S.CERAMIC	C3216 JB 1C 105M-T-A
C238	4510004630	S.ELECTROLYTIC	ECEV1CA100SR
C239	4030006860	S.CERAMIC	C1608 JB 1H 102K-T-A
C240	4030006860	S.CERAMIC	C1608 JB 1H 102K-T-A
C241	4030007090	S.CERAMIC	C1608 CH 1H 470J-T-A
C242	4030007090	S.CERAMIC	C1608 CH 1H 470J-T-A
C243	4030007090	S.CERAMIC	C1608 CH 1H 470J-T-A
C244	4030007090	S.CERAMIC	C1608 CH 1H 470J-T-A
C245	4030007090	S.CERAMIC	C1608 CH 1H 470J-T-A
C246	4030007090	S.CERAMIC	C1608 CH 1H 470J-T-A
C247	4030007090	S.CERAMIC	C1608 CH 1H 470J-T-A
C248	4030007090	S.CERAMIC	C1608 CH 1H 470J-T-A
C249	4030007090	S.CERAMIC	C1608 CH 1H 470J-T-A
C250	4030007090	S.CERAMIC	C1608 CH 1H 470J-T-A
C251	4030007090	S.CERAMIC	C1608 CH 1H 470J-T-A
C252	4030007090	S.CERAMIC	C1608 CH 1H 470J-T-A
C253	4030007090	S.CERAMIC	C1608 CH 1H 470J-T-A
C254	4030007090	S.CERAMIC	C1608 CH 1H 470J-T-A
C255	4030007090	S.CERAMIC	C1608 CH 1H 470J-T-A
C256	4030007090	S.CERAMIC	C1608 CH 1H 470J-T-A
C257	4030007090	S.CERAMIC	C1608 CH 1H 470J-T-A
C258	4030007090	S.CERAMIC	C1608 CH 1H 470J-T-A
C259	4030007090	S.CERAMIC	C1608 CH 1H 470J-T-A
C260	4030007090	S.CERAMIC	C1608 CH 1H 470J-T-A
C261	4030007090	S.CERAMIC	C1608 CH 1H 470J-T-A
C262	4030007090	S.CERAMIC	C1608 CH 1H 470J-T-A
C263	4030007090	S.CERAMIC	C1608 CH 1H 470J-T-A
C264	4030007010	S.CERAMIC	C1608 CH 1H 100D-T-A
C265	4030007090	S.CERAMIC	C1608 CH 1H 470J-T-A
C266	4030007090	S.CERAMIC	C1608 CH 1H 470J-T-A
C267	4030007090	S.CERAMIC	C1608 CH 1H 470J-T-A
C268	4030007090	S.CERAMIC	C1608 CH 1H 470J-T-A
C269	4030007090	S.CERAMIC	C1608 CH 1H 470J-T-A
C270	4030007090	S.CERAMIC	C1608 CH 1H 470J-T-A
C271	4030007090	S.CERAMIC	C1608 CH 1H 470J-T-A

[P]: PMR, [L]: LMR

S.=Surface mount

[MAIN UNIT]

REF NO.	ORDER NO.	DESCRIPTION	
C272	4030007090	S.CERAMIC	C1608 CH 1H 470J-T-A
C273	4030007090	S.CERAMIC	C1608 CH 1H 470J-T-A
C274	4030007090	S.CERAMIC	C1608 CH 1H 470J-T-A
C275	4030007090	S.CERAMIC	C1608 CH 1H 470J-T-A
C276	4030007090	S.CERAMIC	C1608 CH 1H 470J-T-A
C277	4030007090	S.CERAMIC	C1608 CH 1H 470J-T-A
C278	4030007090	S.CERAMIC	C1608 CH 1H 470J-T-A
C279	4030007090	S.CERAMIC	C1608 CH 1H 470J-T-A
C281	4030011600	S.CERAMIC	C1608 JB 1C 104KT-N
C282	4510005430	S.ELECTROLYTIC	ECEV0JA220SR
C283	4030006850	S.CERAMIC	C1608 JB 1H 471K-T-A
C284	4030007090	S.CERAMIC	C1608 CH 1H 470J-T-A
C285	4030006860	S.CERAMIC	C1608 JB 1H 102K-T-A
C286	4030007090	S.CERAMIC	C1608 CH 1H 470J-T-A
C287	4030007090	S.CERAMIC	C1608 CH 1H 470J-T-A
C288	4030006860	S.CERAMIC	C1608 JB 1H 102K-T-A
C289	4030006860	S.CERAMIC	C1608 JB 1H 102K-T-A
C291	4030011600	S.CERAMIC	C1608 JB 1C 104KT-N
C292	4030008920	S.CERAMIC	C1608 JB 1C 473K-T-A
C293	4030006860	S.CERAMIC	C1608 JB 1H 102K-T-A
C295	4030008630	S.CERAMIC	C1608 JF 1C 104Z-T-A
C296	4030008630	S.CERAMIC	C1608 JF 1C 104Z-T-A
C297	4030007090	S.CERAMIC	C1608 CH 1H 470J-T-A
C298	4030007090	S.CERAMIC	C1608 CH 1H 470J-T-A
C299	4030007090	S.CERAMIC	C1608 CH 1H 470J-T-A
C300	4030009910	S.CERAMIC	C1608 CH 1H 040B-T-A
C301	4030009910	S.CERAMIC	C1608 CH 1H 040B-T-A
C302	4030006860	S.CERAMIC	C1608 JB 1H 102K-T-A
C303	4030006860	S.CERAMIC	C1608 JB 1H 102K-T-A
C304	4030007020	S.CERAMIC	C1608 CH 1H 120J-T-A
C306	4030007090	S.CERAMIC	C1608 CH 1H 470J-T-A
C307	4550006320	S.TANTALUM	ECST0JY475R
C308	4030009510	S.CERAMIC	C1608 CH 1H 010B-T-A
C309	4030007090	S.CERAMIC	C1608 CH 1H 470J-T-A
C310	4030007090	S.CERAMIC	C1608 CH 1H 470J-T-A
C311	4030007090	S.CERAMIC	C1608 CH 1H 470J-T-A
C312	4030007090	S.CERAMIC	C1608 CH 1H 470J-T-A
C313	4030007090	S.CERAMIC	C1608 CH 1H 470J-T-A
C314	4030007090	S.CERAMIC	C1608 CH 1H 470J-T-A
C315	4030007090	S.CERAMIC	C1608 CH 1H 470J-T-A
C316	4030007090	S.CERAMIC	C1608 CH 1H 470J-T-A
C317	4030007090	S.CERAMIC	C1608 CH 1H 470J-T-A
C318	4030007010	S.CERAMIC	C1608 CH 1H 100D-T-A
C319	4030011600	S.CERAMIC	C1608 JB 1C 104KT-N
C321	4030007090	S.CERAMIC	C1608 CH 1H 470J-T-A
C322	4030009660	S.CERAMIC	C1608 JF 1C 224Z-T-A
C323	4030007010	S.CERAMIC	C1608 CH 1H 100D-T-A
C324	4030007090	S.CERAMIC	C1608 CH 1H 470J-T-A
C325	4030007090	S.CERAMIC	C1608 CH 1H 470J-T-A
C326	4030007090	S.CERAMIC	C1608 CH 1H 470J-T-A
C327	4030007090	S.CERAMIC	C1608 CH 1H 470J-T-A
C328	4030007090	S.CERAMIC	C1608 CH 1H 470J-T-A
C329	4030007090	S.CERAMIC	C1608 CH 1H 470J-T-A
C330	4030007090	S.CERAMIC	C1608 CH 1H 470J-T-A
C331	4030006850	S.CERAMIC	C1608 JB 1H 471K-T-A
C332	4030007090	S.CERAMIC	C1608 CH 1H 470J-T-A
C333	4030007090	S.CERAMIC	C1608 CH 1H 470J-T-A
C334	4030007090	S.CERAMIC	C1608 CH 1H 470J-T-A
C335	4030007090	S.CERAMIC	C1608 CH 1H 470J-T-A
C336	4030007090	S.CERAMIC	C1608 CH 1H 470J-T-A
C337	4550006000	S.TANTALUM	TEMSVB2 1V 225M-8L
C338	4030009520	S.CERAMIC	C1608 CH 1H 020B-T-A
			[P] [H-band]
	4030006980	S.CERAMIC	C1608 CH 1H 070D-T-A
			[L/ML/MH-band]
C339	4030006860	S.CERAMIC	C1608 JB 1H 102K-T-A
C340	4030006860	S.CERAMIC	C1608 JB 1H 102K-T-A
C341	4030006860	S.CERAMIC	C1608 JB 1H 102K-T-A
C342	4030006860	S.CERAMIC	C1608 JB 1H 102K-T-A
C343	4030006860	S.CERAMIC	C1608 JB 1H 102K-T-A
C344	4030006860	S.CERAMIC	C1608 JB 1H 102K-T-A
C345	4030006860	S.CERAMIC	C1608 JB 1H 102K-T-A
C346	4030006860	S.CERAMIC	C1608 JB 1H 102K-T-A
C347	4030006860	S.CERAMIC	C1608 JB 1H 102K-T-A
C348	4030009660	S.CERAMIC	C1608 JF 1C 224Z-T-A
C349	4030009660	S.CERAMIC	C1608 JF 1C 224Z-T-A
C350	4030006860	S.CERAMIC	C1608 JB 1H 102K-T-A
C351	4030008920	S.CERAMIC	C1608 JB 1C 473K-T-A
J1	6450000140	CONNECTOR	HSJ0807-01-010
J2	6510007080	CONNECTOR	PI28A-02M

[P]: PMR, [L]: LMR

[MAIN UNIT]

REF NO.	ORDER NO.	DESCRIPTION	
J3	6510020510	S.CONNECTOR	FH12-40S-0.5SV
J4	6510018430	S.CONNECTOR	AXN330C038P
J5	6510019250	S.CONNECTOR	B11B-ZR-SM3-TF
J6	6510014960	S.CONNECTOR	B2B-ZR-SM3-TF
W2	7120000470	JUMPER	ERDS2T0
W6	8900004540	CABLE	OPC-453
W7	7030003860	S.JUMPER	ERJ3GE JPW V
W8	7030003860	S.JUMPER	ERJ3GE JPW V
W9	7030003860	S.JUMPER	ERJ3GE JPW V
W10	7030000010	S.JUMPER	MCR10EZHZ JPW (000)
W11	7120000480	S.JUMPER	MJP-0.4-T
W12	7120000480	S.JUMPER	MJP-0.4-T
W13	7030003860	S.JUMPER	ERJ3GE JPW V
W14	7030003860	S.JUMPER	ERJ3GE JPW V
W15	7030003860	S.JUMPER	ERJ3GE JPW V
W16	7030003860	S.JUMPER	ERJ3GE JPW V
EP1	0910050055	PCB	B 5156E
EP2	6910011560	BEAD	HF70BB4.5X5X1.6
EP3	6910006290	BEAD	HF70BB9X5X4.5

S.=Surface mount

SECTION 7 MECHANICAL PARTS

[FRONT UNIT]

REF NO.	ORDER NO.	DESCRIPTION	QTY.
J1	6450001470	Connector 95003-2881	1
W3	8900007680	Cable OPC-741	1
DS1	5030001540	LCD LD-HU10140J	1
EP2	8930044930	LCD contact SRCN-2055-SP-N-W	1
MP1	8210015090	2055 LCD reflector	1
	8210016090	2266 reflector	1
MP2	8930044110	2055 LCD holder	1
	8310045980	2266 plate	1

Ⓒ: LCD type (F410/F420), Ⓔ: LED type (F410S/F420S)

[CHASSIS PARTS]

REF NO.	ORDER NO.	DESCRIPTION	QTY.
J1	6510004880	Connector MR-DS-E 01	1
SP1	2510001030	Speaker VS-57-0837A	1
WS1	8600036130	P1CH	1
MP1	8010017100	2055 Chassis	1
MP2	8010017120	2055 Cover	1
MP3	8210015070	2055 Front panel	1
MP4	8930044820	2055 Front key (A)	1
MP7	8810008660	PH BT M3 X 8 NI-ZU	24
MP8	8930044100	2055 Speaker plate	1
MP9	8930044761	2055 Speaker net-1	1
MP11	8930027480	1126 TR-A clip	2
MP12	8930039890	Insulation sheet (AM)	2

[MAIN UNIT]

REF NO.	ORDER NO.	DESCRIPTION	QTY.
J1	6450000140	Connector HSJ0807-01-010	1
W6	8900004540	Cable OPC-453	1
EP3	6910006290	Bead HF70BB (9 X 5 X 4.5)	2
MP1	8510009980	1705 VCO case	1
MP2	8510010080	1705 VCO cover	1
MP3	8510011460	2055 Filter case	1
MP4	8510011610	2055 Filter cover (A)	1
MP5	8510000210	194 Shield plate	1
MP6	8510005070	599 Shield plate	1
MP7	8930045920	2056 Sponge	1
MP8	8930045930	2056 M-holder	1
MP9	8930046150	Rubber sheet (AK)-1	1
MP10	8930045390	Sponge (FL)	1
MP11	8930045920	2056 Sponge	1
MP12	8930045070	2056 M-plate	1
MP13	8930045920	2056 Sponge	[LMR] only
MP14	8930046770	Thermally sheet (G)	[LMR] only
MP15	8510002280	VCO cover	1
MP16	8930048870	2056 A-Sponge	[H-band] only
MP17	8510002280	VCO cover	[H-band] only
MP18	8930048870	2056 A-Sponge	[H-band] only

[UNPACKING]

REF NO.	ORDER NO.	DESCRIPTION	QTY.
F1	5210000120	Fuse FGB 15A	[PMR] 2
	5210000080	Fuse FGB 20A	[LMR] 2
MC1	Optional product	Microphone EM-99	1
W1	Optional product	Cable OPC-345	[PMR] 1
	Optional product	Cable OPC-346	[LMR] 1
W2	Optional product	Cable OPC-049	1
MP1	8010016380	1542 MOBIL BLACKET (B)	1
MP3	8820000530	Flange volt M4 X 8 NI	4
MP4	8810000470	PH M5 X 12 NI	4
MP5	8810005840	PH A M5 X 20	4
MP6	8850000150	Flat washer M5 NI BS	4
MP7	8850000390	Spring washer M5	4
MP8	8830000120	Nut M5	4
MP9	6910004210	731 Mic hanger set (incl. screw, washer)	1
MP10	8310042780	Label 1705 LCD seal (A)	1

Screw abbreviations BT: Self-tapping PH: Pan head
 FH: Flat head ZK: Black
 NI-ZK: Nickel-Zinc BS: Brass

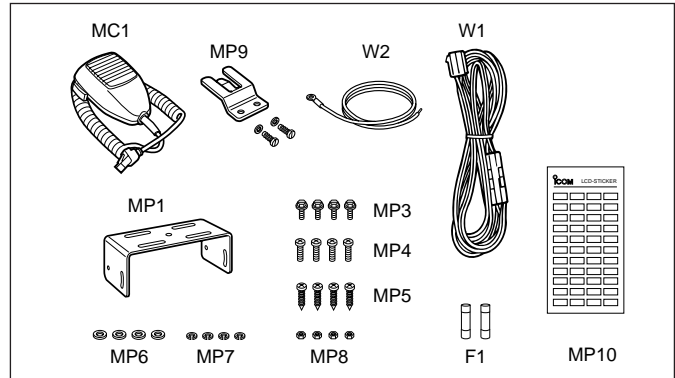

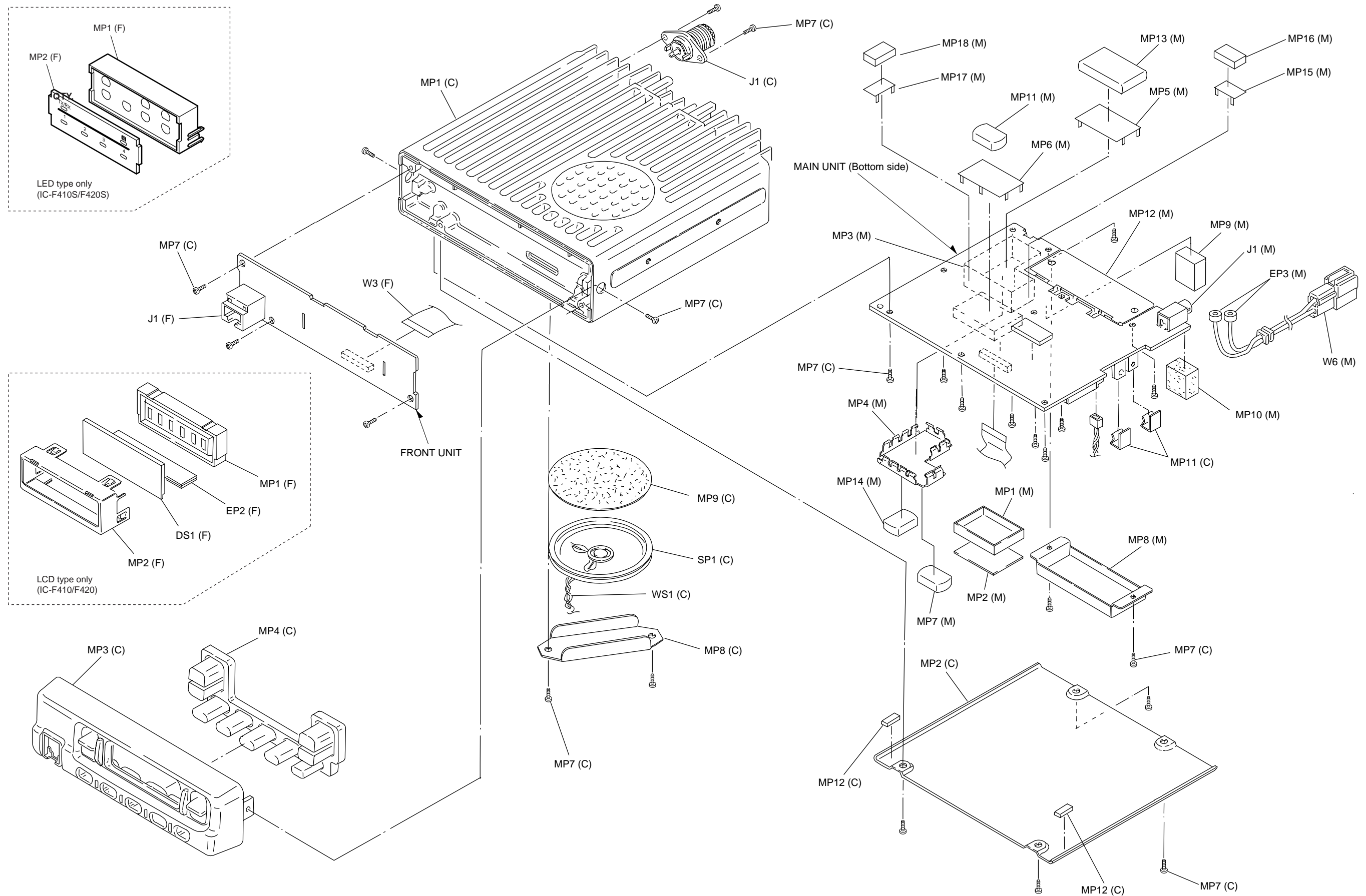







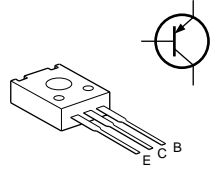







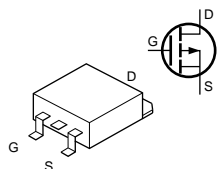
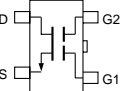
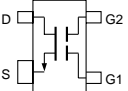
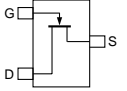
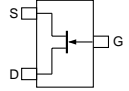
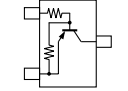
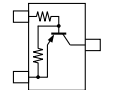
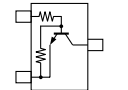
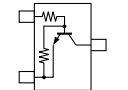
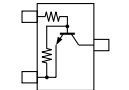
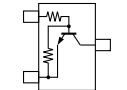









Unit abbreviations (F): FRONT UNIT (M): MAIN UNIT (C): CHASSIS PARTS

SECTION 8 SEMI-CONDUCTOR INFORMATION

• TRANSISTORS AND FET'S

2SB1132 R (Symbol: BARB) 	2SB1143 S 	2SC4081 R (Symbol: BR) 	2SC4215 O (Symbol: QO) 	2SC4703 SE (Symbol: SE) 
2SC5107 O (Symbol: MF) 	2SC5110 O (Symbol: MGO) 	2SD1664 Q (Symbol: DAQ) 	2SJ144 GR (Symbol: VG) 	2SJ377 (Symbol: 4L) 
2SK241 R (TX) (Symbol: DU) 	2SK272 (Symbol: K) 	2SK536 (Symbol: BJ) 	2SK880 GR (Symbol: XG) 	DTA143ZU (Symbol: 113) 
DTA144EU (Symbol: 16) 	DTC114EU (Symbol: 24) 	DTC144EU (Symbol: 26) 	DTC144TU (Symbol: 06) 	DTC363EK (Symbol: H27) 
XP4601 (Symbol: 5C) 	XP6501 (Symbol: 5N) 			

• DIODES

1SS302 (Symbol: C3) 	1SS352 (Symbol: C1) 	1T365 (Symbol: pink line) 	DA221 (Symbol: K) 	DAN202U (Symbol: N) 
DAN204U (Symbol: K) 	HVU350 (Symbol: 4) 	MA77 (Symbol: 4B) 	MA111 (Symbol: 1B) 	MA713 (Symbol: MIN) 
MA8051 M (TX) (Symbol: 5-1) 	MI809 (Symbol: Red dot) 	UM9401F 		

SECTION 9 BOARD LAYOUTS

9-1 FRONT UNIT (IC-F410/F420)

• TOP VIEW

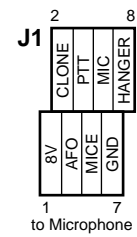
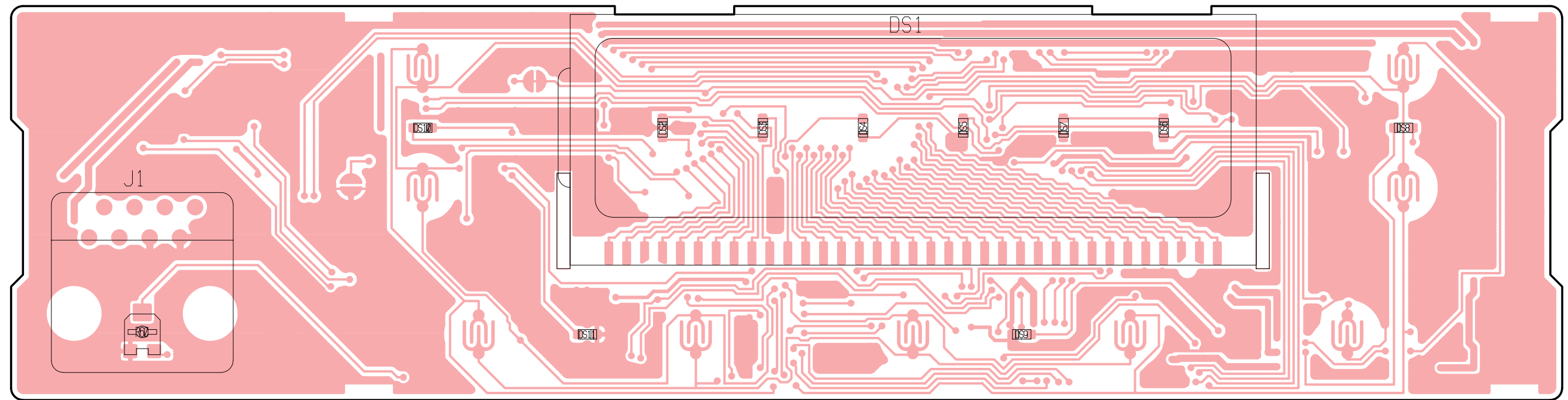

● BOTTOM VIEW

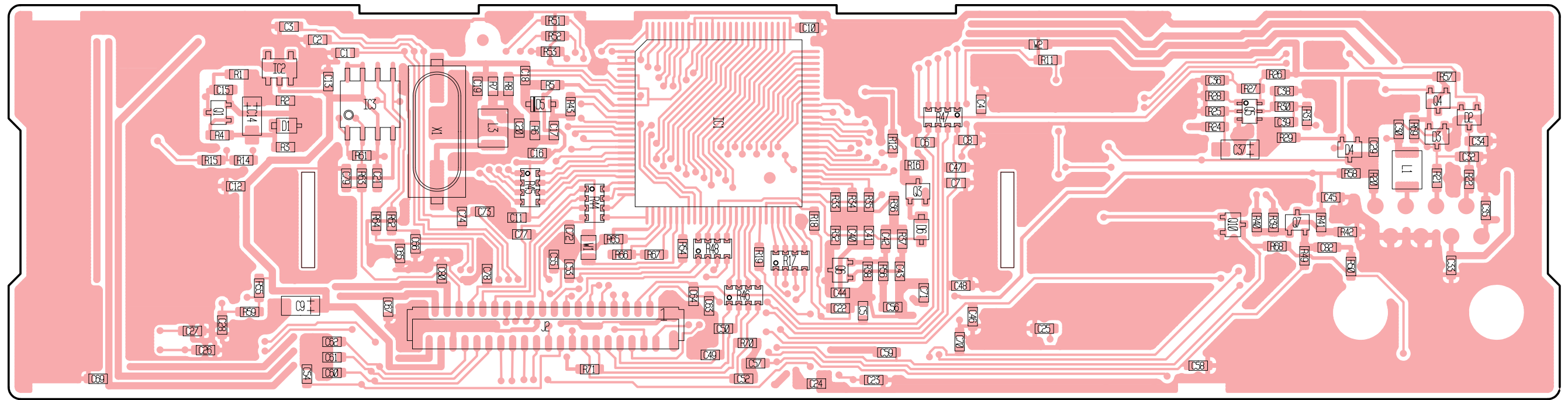

39	5V	AFO	SI	OPT3	OPT2	OPT1	OPV3	OPV2	OPV1	PTT	PTTIN	DET	PWON	EXPTT	DIMIN	SO	SCK	SD	LVIN	GND	1
J2	8V	CPU5V	GND	OPINT	OPCS	BUSY	BEEPOUT	tone	BEEP	DTCSIN	RFATT	NOIS	UNLK	EXEN	EXST	DAST	PLST	VIN	TEMP	MIC	2
40	to MAIN unit J3																				2

9-2 FRONT UNIT (IC-F410S/F420S)

● TOP VIEW

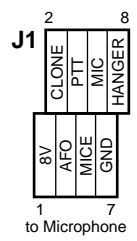
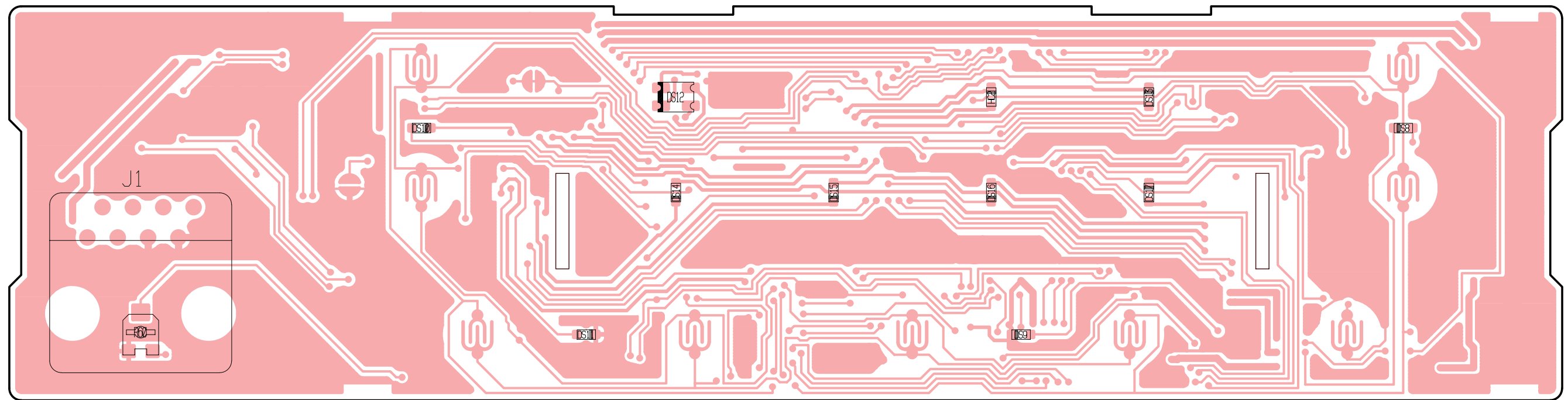

● BOTTOM VIEW

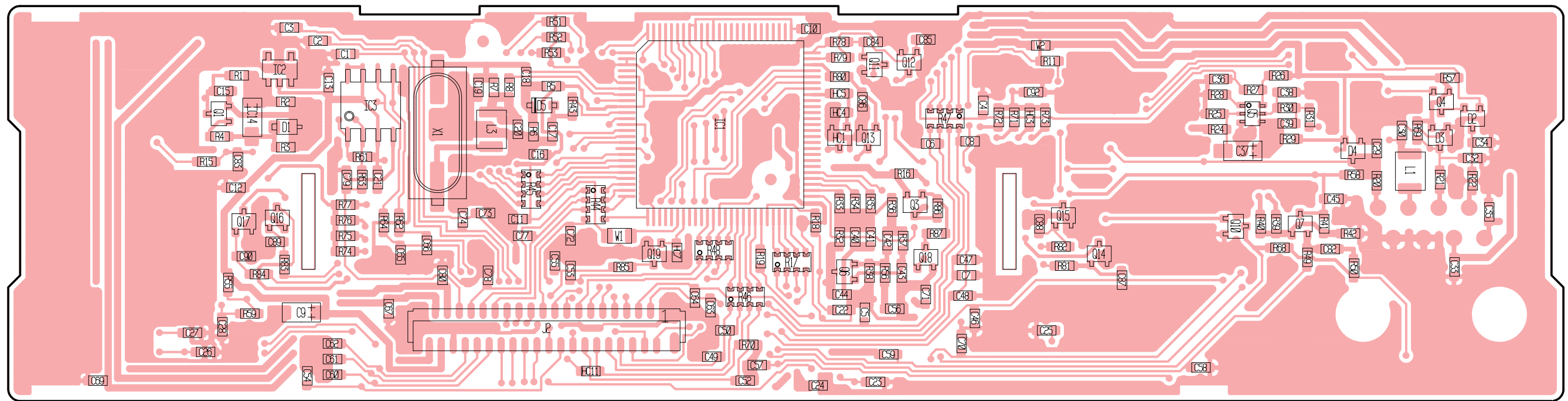

39	5V	AFO	SI	OPT3	OPT2	OPT1	OPV3	OPV2	OPV1	PIT	PTTN	DET	PWON	EXPTT	DIMIN	SO	SOK	SD	LVIN	GND	1
J2	8V	CPU5V	GND	OPINT	OPCS	BUSY	BEEP	BEFP	DTCSIN	RFATT	NOIS	UNLK	EXEN	EXST	DAST	PLST	VIN	TEMP	MIC	GND	2
40	to MAIN unit J3																				

9-3 MAIN UNIT

● TOP VIEW

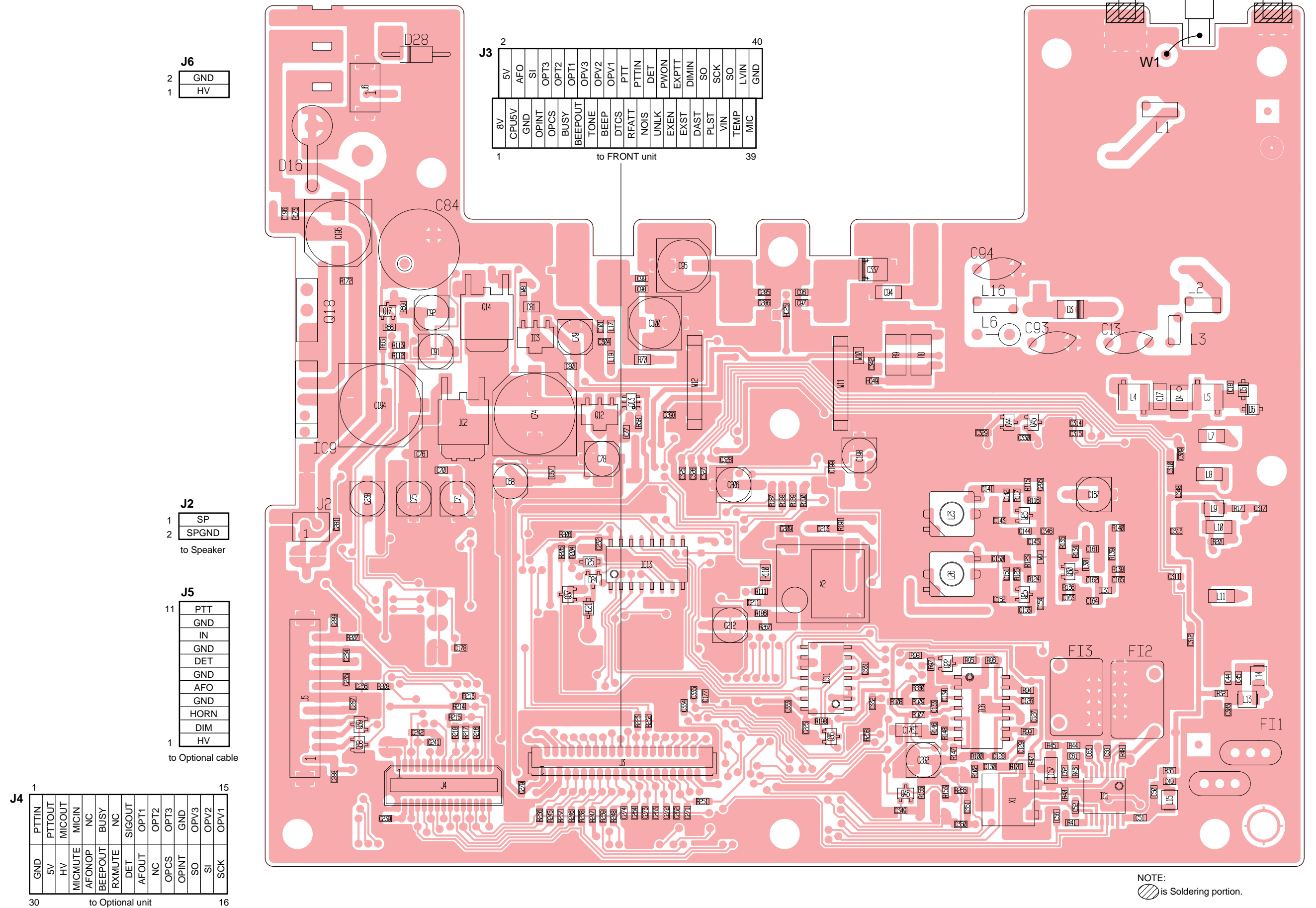

J6

2	GND
1	HV

J3

2	5V	AFO	SI	OPT3	OPT2	OPT1	OPV3	OPV2	OPV1	PTT	PTTIN	DET	NOIS	UNLK	PWON	EXPTT	DIMIN	SO	SCK	SO	LVIN	GND	40
1	8V	CPU5V	GND	OPINT	OPCS	BUSY	BEEP	BEFP	DTCS	RFATT	NOIS	UNLK	EXEN	EXST	DAST	PLST	VIN	TEMP	MIC				39

to FRONT unit

J2

1	SP
2	SPGND

to Speaker

J5

11	PTT
	GND
	IN
	GND
	DET
	GND
	AFO
	GND
	HORN
	DIM
1	HV

to Optional cable

J4

1	PTTIN	15
	PTTOUT	
	MICOUT	
	MICIN	
	MICMUTE	
	AFONOP	
	BEFP	
	RXMUTE	
	DET	
	SIGOUT	
	AFOUT	
	NC	
	OPT1	
	OPT2	
	OPT3	
	GND	
	OPV3	
	SI	
	OPV2	
	SCK	
30		16

to Optional unit

NOTE:
 is Soldering portion.

● BOTTOM VIEW

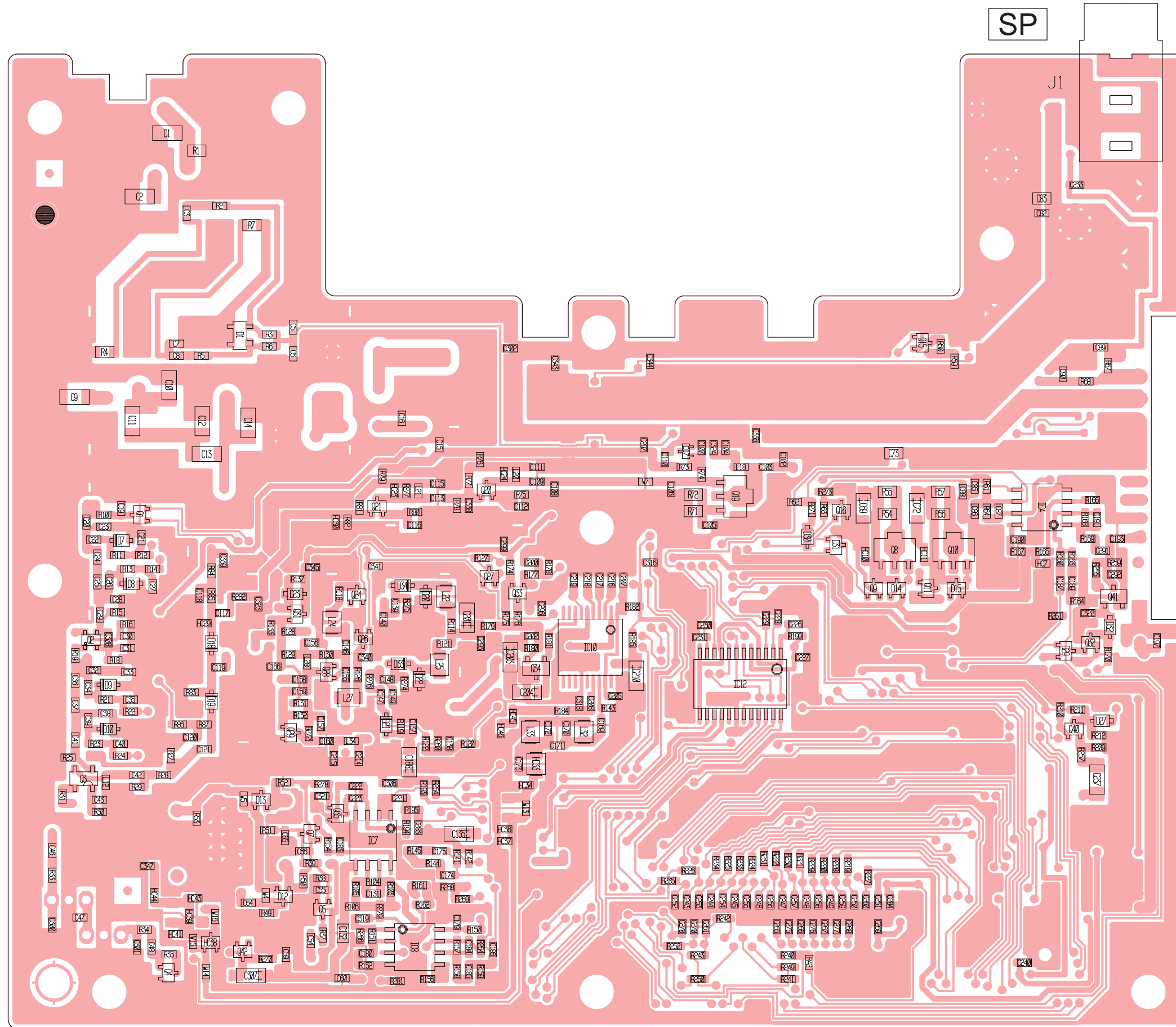

SECTION 10 BLOCK DIAGRAM

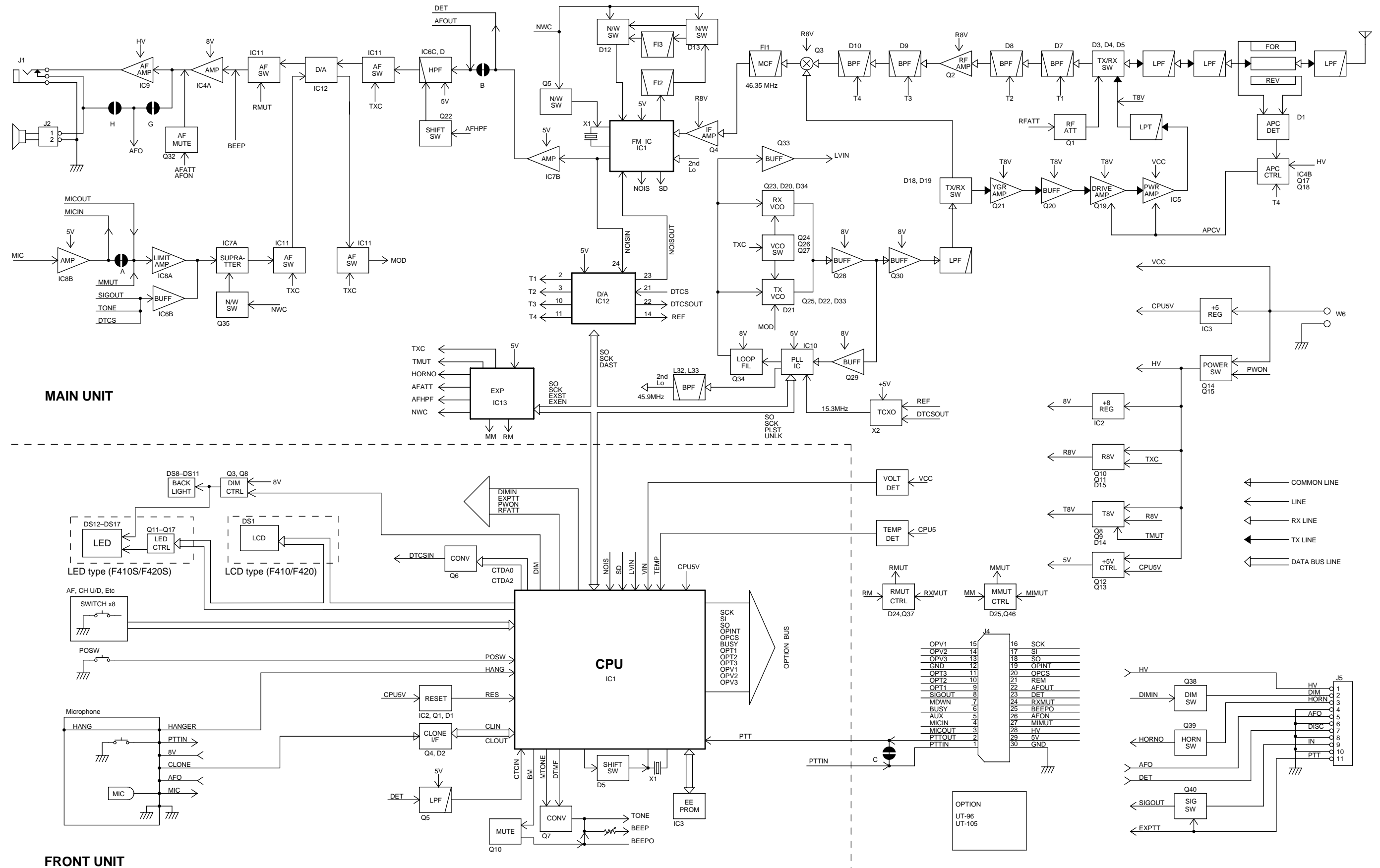

SECTION 11 VOLTAGE DIAGRAM

FRONT UNIT

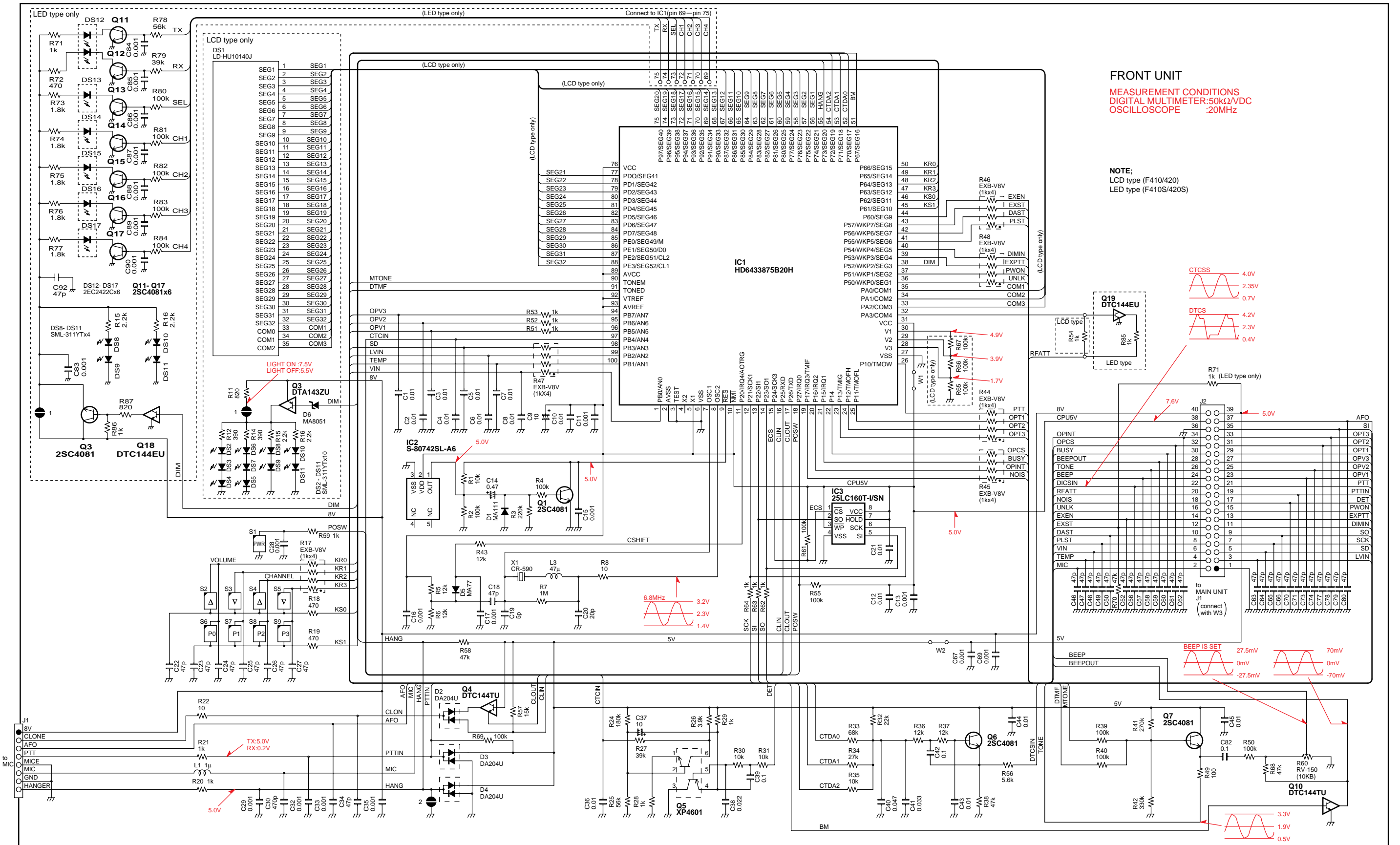

FRONT UNIT
 MEASUREMENT CONDITIONS
 DIGITAL MULTIMETER: 50kΩ/VDC
 OSCILLOSCOPE : 20MHz

NOTE:
 LCD type (F410/420)
 LED type (F410S/420S)

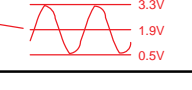
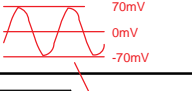
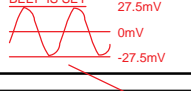
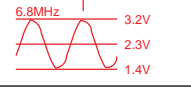
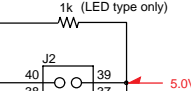
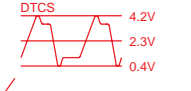
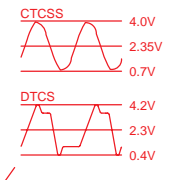

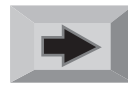
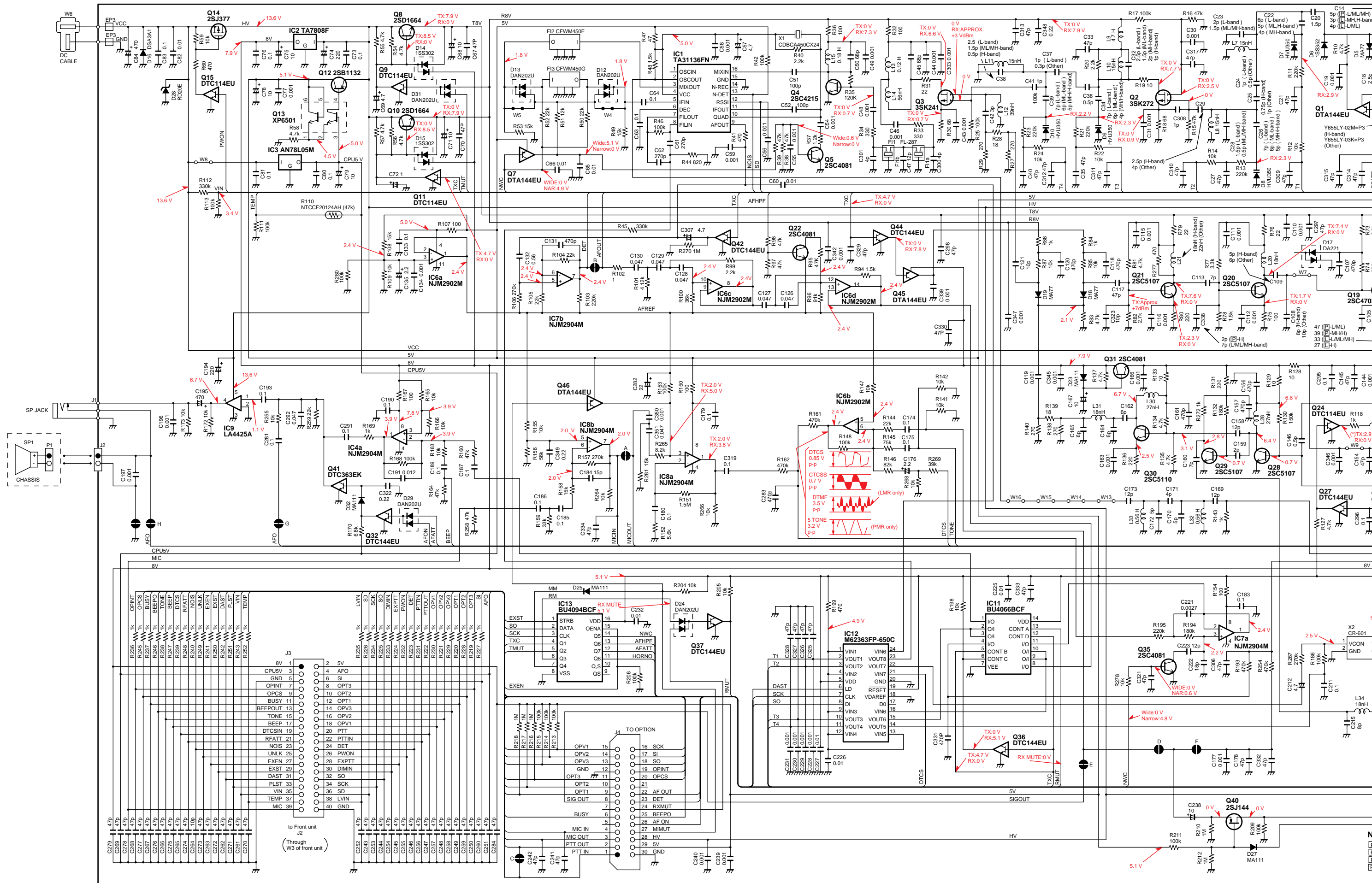

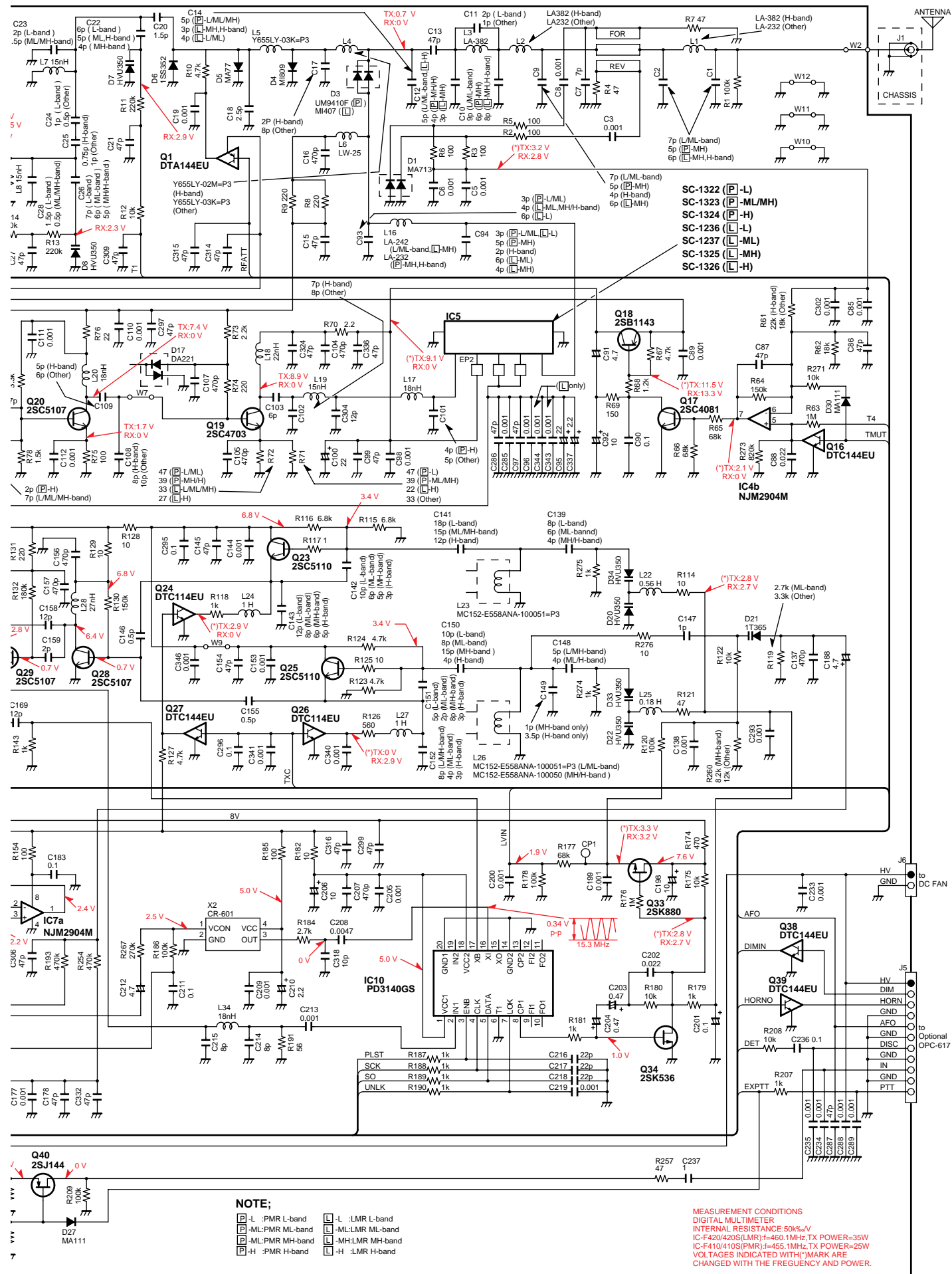

COMPLETE VIEW

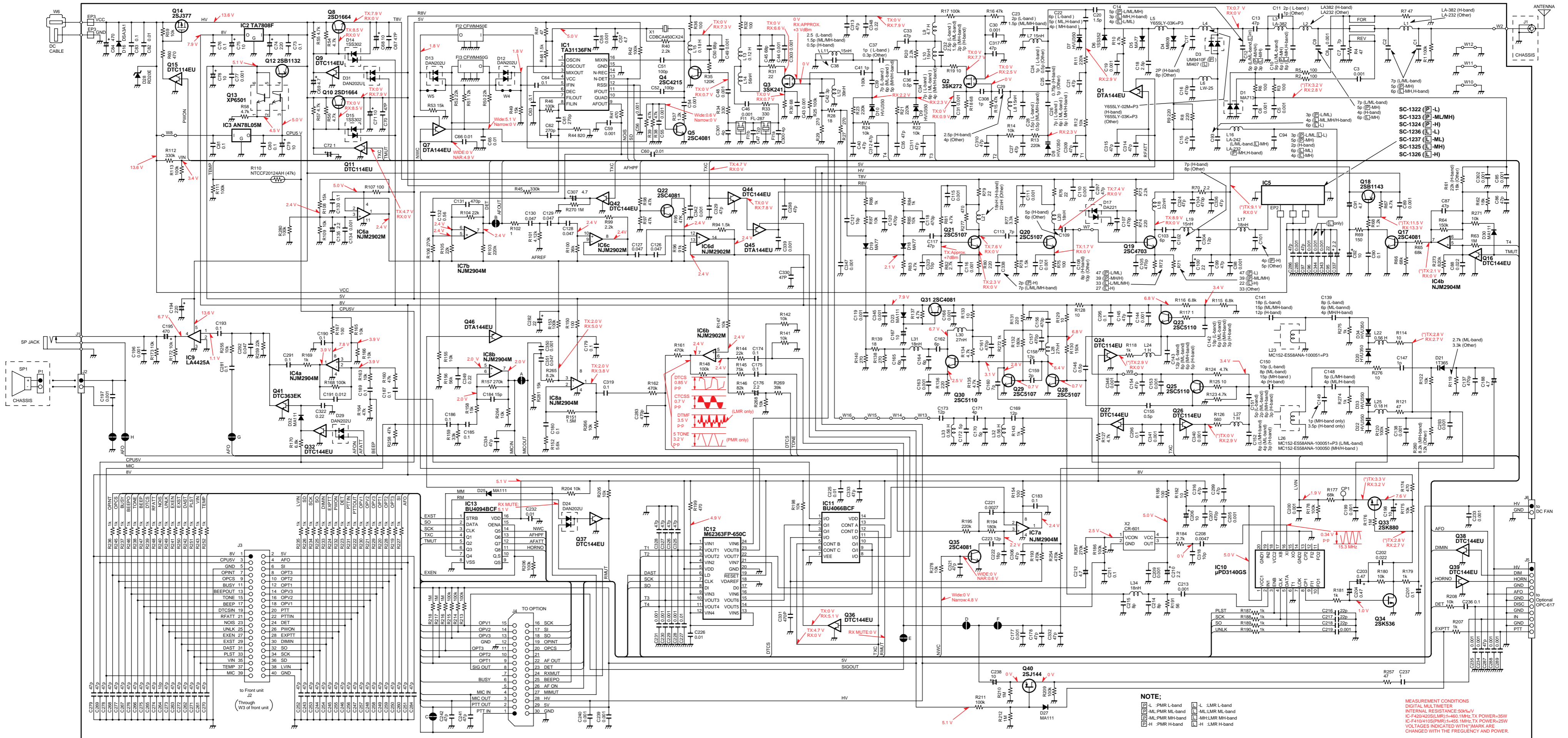

Icom Inc.

6-9-16, Kamihigashi, Hirano-ku, Osaka 547-0002, Japan
Phone : 06 6793 5302
Fax : 06 6793 0013

Icom America Inc.

<Corporate Headquarters>
2380 116th Avenue N.E., Bellevue, WA 98004, U.S.A.
Phone : (425) 454-8155 Fax : (425) 454-1509
URL : <http://www.icomamerica.com>
<Customer Service>
Phone : (425) 454-7619

Icom Canada

A Division of Icom America Inc.
3071 #5 Road, Unit 9, Richmond, B.C., V6X 2T4, Canada
Phone : (604) 273-7400 Fax : (604) 273-1900

Icom (Australia) Pty. Ltd.

A.C.N. 006 092 575
290-294 Albert Street, Brunswick, Victoria, 3056, Australia
Phone : 03 9387 0666 Fax : 03 9387 0022
URL : <http://www.icom.net.au>

Asia Icom Inc.

6F No. 68, Sec. 1 Cheng-Teh Road, Taipei, Taiwan R.O.C.
Phone : (02) 2559 1899 Fax : (02) 2559 1874

Icom (Europe) GmbH

Communication Equipment
Himmelgeister Str. 100, D-40225 Düsseldorf, Germany
Phone : 0211 346047 Fax : 0211 333639
URL : <http://www.icomeurope.com>

Icom Spain S.L.

Ctra. de Gracia a Manresa Km. 14,750
08190 Sant Cugat del Valles Barcelona, SPAIN
Phone : (93) 590 26 70 Fax : (93) 589 04 46
URL : <http://www.icomspain.com>

Icom (UK) Ltd.

Unit 9, Sea St., Heme Bay, Kent, CT6 8LD, U.K.
Phone : 01227 741741 Fax : 01227 741742
URL : <http://www.icomuk.co.uk>

Icom France S.a

Zac de la Plaine, Rue Brindejonc des Moulinais
BP 5804, 31505 Toulouse Cedex, France
Phone : 561 36 03 03 Fax : 561 36 03 00
URL : <http://www.icom-france.com>

Count on us!

Icom Inc.

6-9-16, Kamihigashi, Hirano-ku Osaka 547-0002, Japan

A-5560SI-SU
© 1999 by Icom Inc.